

# DATA SHEET

## **P8xC557E8** 8-bit microcontroller

Product specification  
File under Integrated Circuits, IC20

1999 Mar 12

**8-bit microcontroller****P8xC557E8**

<b>CONTENTS</b>	15	<b>POWER REDUCTION MODES</b>
1	15.1	Idle mode
2	15.2	Power-down mode
2.1	15.3	Wake-up from Power-down mode
2.2	15.4	Status of external pins
3	15.5	Power Control Register (PCON)
4	16	<b>OSCILLATOR CIRCUITS</b>
5	16.1	XTAL1; XTAL2 oscillator: standard 80C51
6	16.2	XTAL3; XTAL4 oscillator: 32 kHz PLL oscillator (with Seconds timer)
6.1	17	<b>RESET CIRCUITRY</b>
6.2	17.1	Power-on Reset
7	18	<b>INSTRUCTION SET</b>
8	18.1	Addressing modes
8.1	18.2	80C51 family instruction set
8.2	18.3	Instruction set description
8.3	19	<b>LIMITING VALUES</b>
9	20	<b>DC CHARACTERISTICS</b>
10	21	<b>AC CHARACTERISTICS</b>
10.1	22	<b>EPROM CHARACTERISTICS</b>
10.2	22.1	Programming and verification
10.3	22.2	Security
11	23	<b>SPECIAL FUNCTION REGISTERS OVERVIEW</b>
11.1	24	<b>PACKAGE OUTLINES</b>
11.2	25	<b>SOLDERING</b>
11.3	25.1	Introduction
11.4	25.2	Reflow soldering
11.5	25.3	Wave soldering
11.6	25.4	Repairing soldered joints
11.7	26	<b>DEFINITIONS</b>
11.8	27	<b>LIFE SUPPORT APPLICATIONS</b>
12	28	<b>PURCHASE OF PHILIPS I<sup>2</sup>C COMPONENTS</b>
12.1		
12.2		
12.3		
13		
13.1		
13.2		
14		
14.1		
14.2		
14.3		
14.4		
14.5		



## 8-bit microcontroller

## P8xC557E8

### 1 FEATURES

- 80C51 Central Processing Unit (CPU)
- 64 kbytes ROM (only P83C557E8)
- 64 kbytes EPROM (only P87C557E8)
- ROM/EPROM Code protection
- 2048 bytes RAM, expandable externally to 64 kbytes
- Two standard 16-bit timers/counters
- An additional 16-bit timer/counter coupled to four capture registers and three compare registers
- A 10-bit Analog-to-Digital Converter (ADC) with eight multiplexed analog inputs and programmable autoscan
- Two 8-bit resolution, Pulse Width Modulation outputs
- Five 8-bit I/O ports plus one 8-bit input port shared with analog inputs
- I<sup>2</sup>C-bus serial I/O port with byte oriented master and slave functions
- Full-duplex UART compatible with the standard 80C51
- On-chip Watchdog Timer
- 15 interrupt sources with 2 priority levels (2 to 6 external sources possible)
- Phase-Locked Loop (PLL) oscillator with 32 kHz reference and software-selectable system clock frequency
- Seconds timer
- Software enable/disable of ALE output pulse
- Electromagnetic compatibility improvements
- Wake-up from Power-down by external or seconds interrupt
- Frequency range for 80C51-family standard oscillator: 3.5 to 16 MHz
- Extended temperature range: -40 to +85 C
- Supply voltage: 4.5 to 5.5 V.

### 2 GENERAL DESCRIPTION

The 8-bit microcontrollers P80C557E8, P83C557E8 and P87C557E8 - hereafter referred to as P8xC557E8 - are manufactured in an advanced CMOS process and are derivatives of the 80C51 microcontroller family.

The P8xC557E8 contains a volatile 2048 bytes read/write Data Memory, five 8-bit I/O ports, one 8-bit input port, two 16-bit timer/event counters (identical to the timers of the 80C51), an additional 16-bit timer coupled to capture and compare latches, a 15-source, two-priority-level, nested interrupt structure, an 8-input ADC, a dual Digital-to-Analog Converter (DAC), Pulse Width Modulated interface, two serial interfaces (UART and I<sup>2</sup>C-bus), a Watchdog Timer, an on-chip oscillator and timing circuits.

The P8xC557E8 is available in 3 versions:

- P80C557E8: ROMless version
- P83C557E8: containing a non-volatile 64 kbytes mask programmable ROM
- P87C557E8: containing 64 kbytes programmable EPROM/OTP.

The P8xC557E8 is a control-oriented CPU with on-chip Program and Data Memory; it cannot be extended with external Program Memory. It can access up to 64 kbytes of external Data Memory. For systems requiring extra capability, the P8xC557E8 can be expanded using standard TTL compatible memories and peripherals.

In addition, the P8xC557E8 has two software selectable reduced power modes: Idle mode and Power-down mode. The Idle mode freezes the CPU while allowing the RAM, timers, serial ports, and interrupt system to continue functioning. The Power-down mode saves the RAM contents but freezes the oscillator, causing all other chip functions to be inoperative. The Power-down mode can be terminated by an external reset, by the seconds interrupt and by any one of the two external interrupts; see Section 15.3.

The device also functions as an arithmetic processor having facilities for both binary and BCD arithmetic as well as bit-handling capabilities. The instruction set of the P8xC557E8 is the same as the 80C51 and consists of over 100 instructions: 49 one-byte, 45 two-byte, and 17 three-byte. With a 16 MHz system clock, 58% of the instructions are executed in 0.75  $\mu$ s and 40% in 1.5  $\mu$ s. Multiply and divide instructions require 3  $\mu$ s.

## 8-bit microcontroller

## P8xC557E8

**2.1 Electromagnetic Compatibility (EMC)**

Primary attention is paid to the reduction of electromagnetic emission of the microcontroller P8xC557E8. The following features reduce the electromagnetic emission and additionally improve the electromagnetic susceptibility:

- Four digital part supply voltage pins ( $V_{DD1}$  to  $V_{DD4}$ ) and four digital ground pins ( $V_{SS1}$  to  $V_{SS4}$ ) are placed as pairs of  $V_{DDn}$  and  $V_{SSn}$  at two adjacent pins, at each side of the package.
- Separated  $V_{DD}$  pins for the internal logic and the port buffers.
- Internal decoupling capacitance improves the EMC radiation behaviour and the EMC immunity.
- External capacitors should be connected across associated  $V_{DDn}$  and  $V_{SSn}$  pins (i.e.  $V_{DD1}$  and  $V_{SS1}$ ). Lead length should be as short as possible. Ceramic chip capacitors are recommended (100 nF).

**2.2 Recommendation on ALE**

For applications that require no external memory or temporarily no external memory: the ALE output signal (pulses at a frequency of  $\frac{1}{6} \times f_{OSC}$ ) can be disabled under software control (bit RFI; SFR: PCON.5); if disabled, no ALE pulse will occur. ALE pin will be pulled down internally, switching an external address latch to a quiet state. The MOVX instruction will still toggle ALE (external Data Memory is accessed). ALE will retain its normal HIGH value during Idle mode and a LOW value during Power-down mode while in the 'RFI reduction mode'.

Additionally during internal access ( $\overline{EA} = 1$ ) ALE will toggle normally when the address exceeds the internal Program Memory size. During external access ( $\overline{EA} = 0$ ) ALE will always toggle normally, whether the flag 'RFI' is set or not.

**3 ORDERING INFORMATION**

TYPE NUMBER	PACKAGE			FREQUENCY RANGE (MHZ)	TEMPERATURE RANGE (°C)
	NAME	DESCRIPTION	VERSION		
P80C557E8EFB <sup>(1)</sup>	QFP80	plastic quad flat package; 80 leads (lead length 1.95 mm); body 14 × 20 × 2.8 mm	SOT318-2	3.5 to 16	-40 to +85
P83C557E8EFB/hnn <sup>(2)</sup>					
P87C557E8EFB <sup>(3)</sup>					

**Notes**

1. ROMless type.
2. ROM coded type; 'hnn' denotes the ROM code number.
3. EPROM/OTP type.

8-bit microcontroller

P8xC557E8

4 BLOCK DIAGRAM

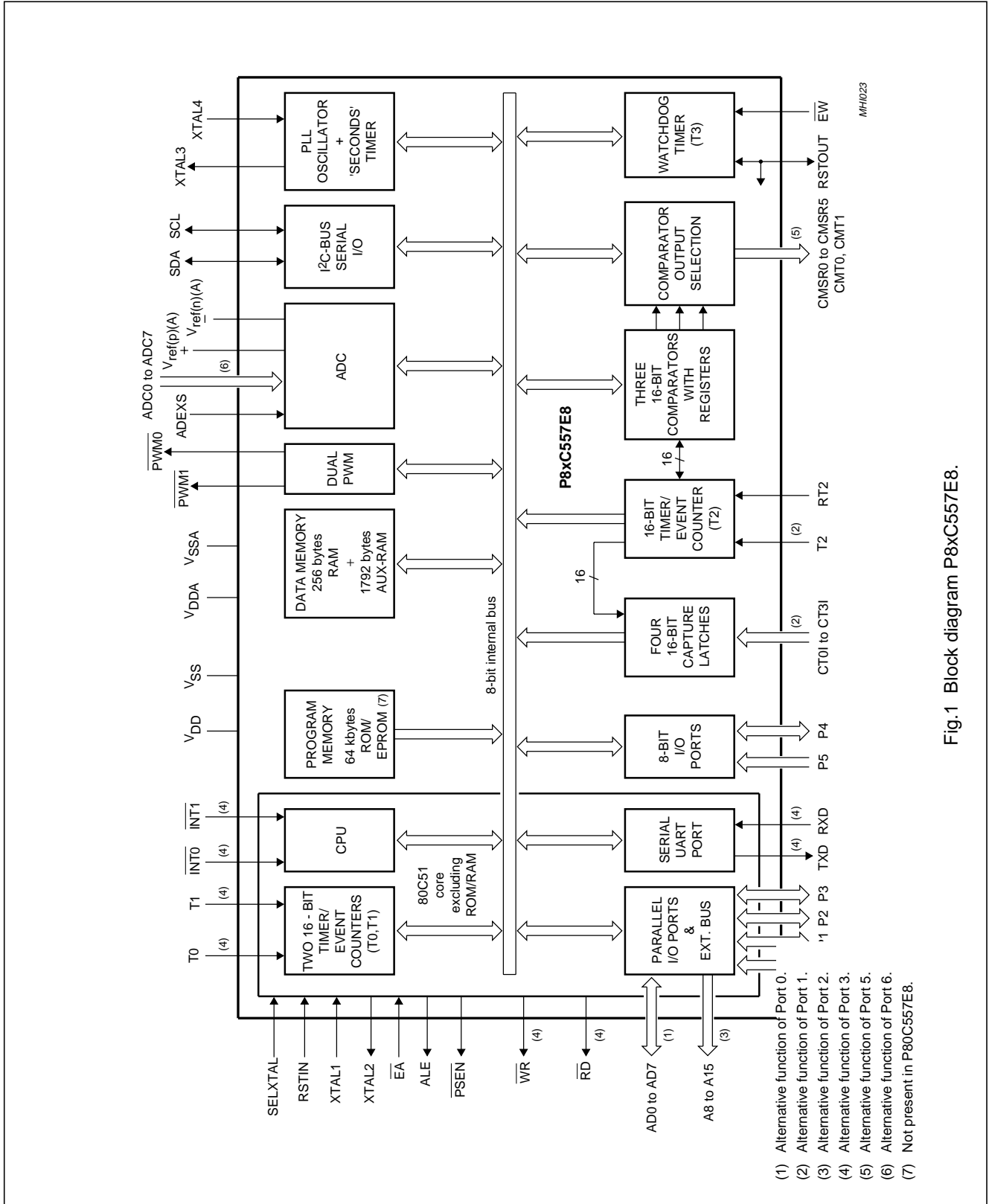
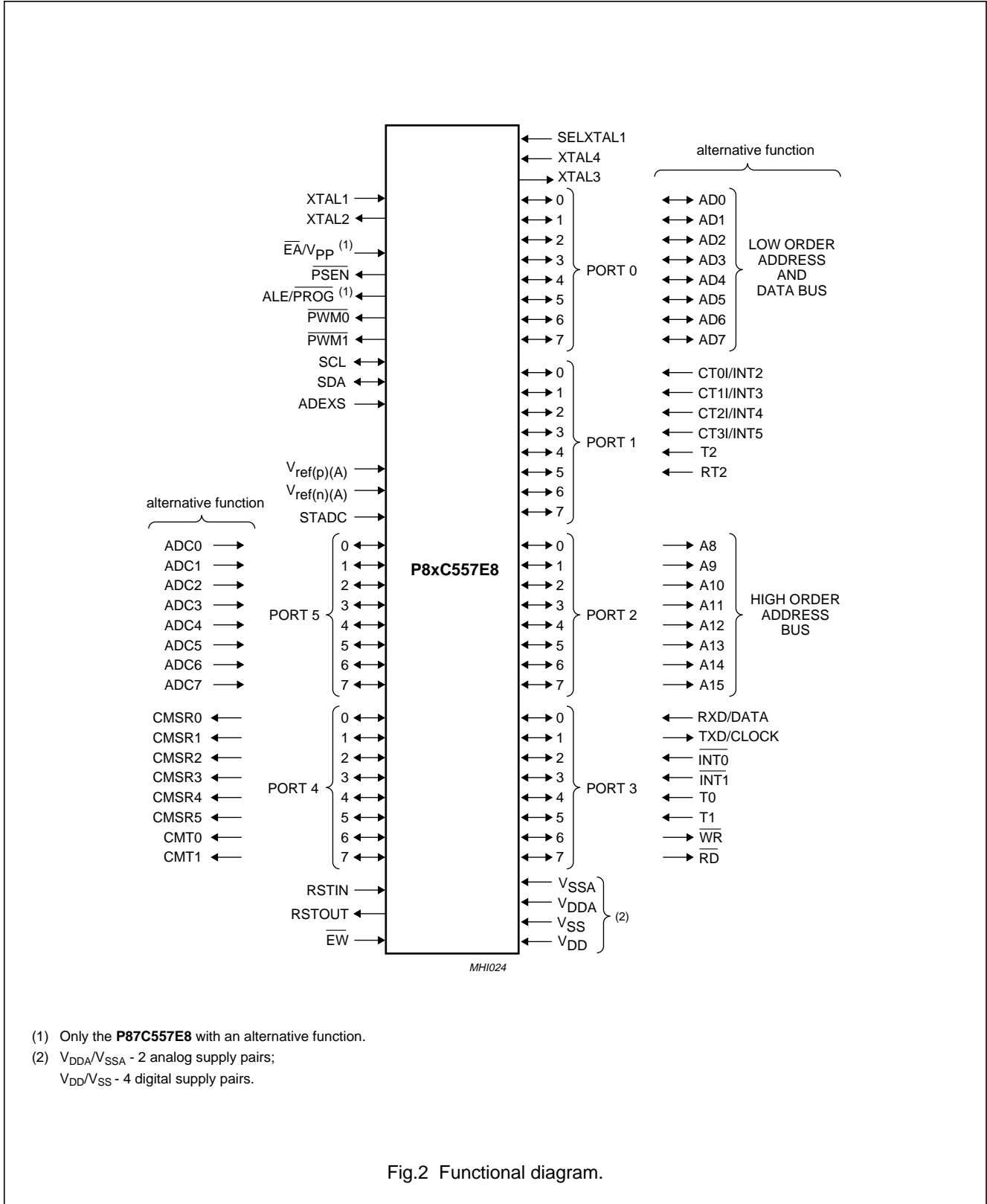

Fig.1 Block diagram P8xC557E8.

8-bit microcontroller

P8xC557E8

5 FUNCTIONAL DIAGRAM



(1) Only the **P87C557E8** with an alternative function.  
 (2)  $V_{DDA}/V_{SSA}$  - 2 analog supply pairs;  
 $V_{DD}/V_{SS}$  - 4 digital supply pairs.

Fig.2 Functional diagram.

8-bit microcontroller

P8xC557E8

6 PINNING INFORMATION

6.1 Pinning diagram

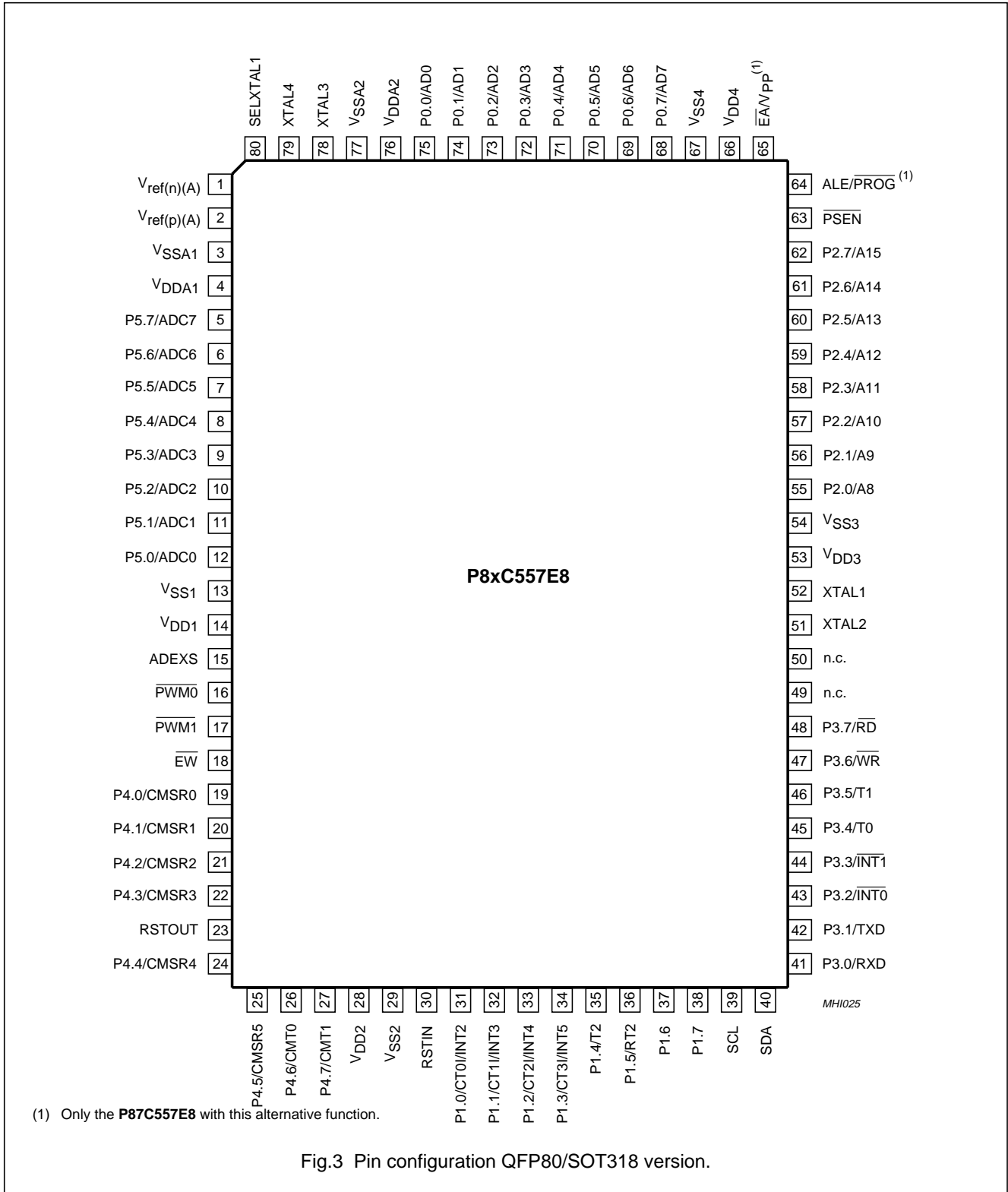

Fig.3 Pin configuration QFP80/SOT318 version.

## 8-bit microcontroller

## P8xC557E8

## 6.2 Pin description

**Table 1** Pin description for QFP80 (SOT318-2)

To avoid a 'latch-up' effect at power-on:  $V_{SS} - 0.5\text{ V} < \text{'voltage at any pin at any time'} < V_{DD} + 0.5\text{ V}$ .

SYMBOL	PIN	DESCRIPTION
$V_{ref(n)(A)}$	1	<b>Low-end of ADC</b> reference resistor.
$V_{ref(p)(A)}$	2	<b>High-end of ADC</b> reference resistor.
$V_{SSA1}$	3	<b>Ground</b> , analog part. For ADC receiver and reference voltage.
$V_{DDA1}$	4	<b>Power supply</b> , analog part (+5 V). For ADC receiver and reference voltage.
P5.7/ADC7 to P5.0/ADC0	5 to 12	<b>Port 5 (P5.7 to P5.0)</b> : 8-bit input port lines; <b>ADC7 to ADC0</b> : 8 input channels to the ADC.
$V_{SS1}$ to $V_{SS4}$	13, 29, 54, 67	<b>Ground</b> ; digital part; circuit ground potential. $V_{SS1}$ , $V_{SS2}$ , $V_{SS4}$ must be connected, $V_{SS3}$ is internally connected to digital ground, but should be connected externally.
$V_{DD1}$ to $V_{DD4}$	14, 28, 53, 66	<b>Power supply</b> , digital part (+5 V). Power supply pins during normal operation and power reduction modes. All pins must be connected.
ADEXS	15	<b>Start ADC operation</b> . Input starting ADC, triggered by a programmable edge; ADC operation can also be started by software. This pin must not float.
$\overline{\text{PWM0}}$	16	<b>Pulse Width Modulation output 0</b> .
$\overline{\text{PWM1}}$	17	<b>Pulse Width Modulation output 1</b> .
$\overline{\text{EW}}$	18	<b>Enable Watchdog Timer (WDT)</b> : enable for T3 Watchdog Timer and disable Power-down mode. This pin must not float.
P4.0/CMSR0 to P4.5/CMSR5	19 to 22, 24, 25	<b>Port 4 (P4.0 to P4.7)</b> : 8-bit quasi-bidirectional I/O port lines; <b>CMSR0 to CMSR5</b> : compare and set/reset outputs for Timer T2;
P4.6/CMT0 to P4.7/CMT1	26, 27	<b>CMT0 to CMT1</b> : compare and toggle outputs for Timer T2.
RSTOUT	23	<b>Reset output</b> of the P8xC557E8 for resetting peripheral devices during initialization and Watchdog Timer overflow.
RSTIN	30	<b>Reset input</b> to reset the P8xC557E8.
P1.0/CT0/INT2 to P1.3/CT3/INT5	31 to 34	<b>Port 1 (P1.0 to P1.7)</b> : 8-bit quasi-bidirectional I/O port lines; <b>CT0 to CT3</b> : Capture timer inputs for Timer T2;
P1.4/T2 to P1.5/RT2	35, 36	<b>INT2 to INT5</b> : external interrupts 2 to 5; <b>T2</b> : T2 event input (rising edge triggered); <b>RT2</b> : T2 timer reset input (rising edge triggered).
P1.6 to P1.7	37 to 38	
SCL	39	<b>I<sup>2</sup>C-bus serial clock I/O port</b> . If SCL is not used, it must be connected to $V_{SS}$ .
SDA	40	<b>I<sup>2</sup>C-bus serial data I/O port</b> . If SDA is not used, it must be connected to $V_{SS}$ .
P3.0/RXD	41	<b>Port 3 (P3.0 to P3.7)</b> : 8-bit quasi-bidirectional I/O port lines;
P3.1/TXD	42	<b>RXD</b> : Serial input port;
P3.2/ $\overline{\text{INT0}}$	43	<b>TXD</b> : Serial output port;
P3.3/ $\overline{\text{INT1}}$	44	<b>INT0</b> : External interrupt input 0;
P3.4/T0	45	<b>INT1</b> : External interrupt input 1;
P3.5/T1	46	<b>T0</b> : Timer 0 external interrupt input;
P3.6/ $\overline{\text{WR}}$	47	<b>T1</b> : Timer 1 external interrupt input;
P3.7/ $\overline{\text{RD}}$	48	<b>WR</b> : External Data Memory Write strobe; <b>RD</b> : External Data Memory Read strobe.
n.c.	49, 50	Not connected pins.



## 8-bit microcontroller

## P8xC557E8

SYMBOL	PIN	DESCRIPTION
XTAL2	51	<b>Crystal pin 2:</b> output of the inverting amplifier that forms the oscillator. Left open-circuit when an external oscillator clock is used.
XTAL1	52	<b>Crystal pin 1:</b> input to the inverting amplifier that forms the oscillator, and input to the internal clock generator. Receives the external oscillator clock signal when an external oscillator is used. Must be connected to logic HIGH if the PLL oscillator is selected (SELXTAL1 = LOW).
P2.0/A08 to P2.7/A15	55 to 62	<b>Port 2 (P2.0 to P2.7):</b> 8-bit quasi-bidirectional I/O port lines; <b>A08 to A15:</b> High-order address byte for external memory.
$\overline{\text{PSEN}}$	63	<b>Program Store Enable</b> output: read strobe to the external Program Memory via Ports 0 and 2. Is activated twice each machine cycle during fetches from external Program Memory. When executing out of external Program Memory two activations of $\overline{\text{PSEN}}$ are skipped during each access to external Data Memory. $\overline{\text{PSEN}}$ is not activated (remains HIGH) during no fetches from external Program Memory. $\overline{\text{PSEN}}$ can sink/source 8 LSTTL inputs. It can drive CMOS inputs without external pull-ups.
$\overline{\text{ALE}}/\overline{\text{PROG}}$	64	<b>Address Latch Enable</b> output. Latches the low byte of the address during access of external memory in normal operation. It is activated every six oscillator periods except during an external Data Memory access. ALE can sink/source 8 LSTTL inputs. It can drive CMOS inputs without an external pull-up. To prohibit the toggling of ALE pin (RFI noise reduction) the bit RFI (SFR: PCON.5) must be set by software; see Section 2.2. <b>PROG:</b> the programming pulse input; alternative function for the P87C557E8.
$\overline{\text{EA}}/V_{\text{PP}}$	65	<b>External Access</b> input. If, during reset, $\overline{\text{EA}}$ is held at a TTL level HIGH the CPU executes out of the internal Program Memory. If, during reset, $\overline{\text{EA}}$ is held at a TTL level LOW the CPU executes out of external Program Memory via Port 0 and Port 2. $\overline{\text{EA}}$ is not allowed to float. $\overline{\text{EA}}$ is latched during reset and don't care after reset. <b>V<sub>PP</sub>:</b> the programming supply voltage; alternative function for the P87C557E8.
P0.7/AD7 to P0.0/AD0	68 to 75	<b>Port 0 (P0.7 to P0.0):</b> 8-bit open-drain bidirectional I/O port lines; <b>AD7 to AD0:</b> Multiplexed Low-order address and Data bus for external memory.
V <sub>DDA2</sub>	76	<b>Power supply</b> , analog part (+5 V). For PLL oscillator.
V <sub>SSA2</sub>	77	<b>Ground</b> , analog part. For PLL oscillator.
XTAL3	78	<b>Crystal pin 3:</b> output of the inverting amplifier that forms the 32 kHz oscillator.
XTAL4	79	<b>Crystal pin 2:</b> input to the inverting amplifier that forms the 32 kHz oscillator. XTAL3 is pulled LOW if the PLL oscillator is not selected (SELXTAL1 = 1) or if reset is active.
SELXTAL1	80	SELXTAL1 = HIGH, selects the HF oscillator, using the XTAL1/XTAL2 crystal. If SELXTAL1 = LOW the PLL is selected for clocking of the controller, using the XTAL3/XTAL4 crystal.

---

## 8-bit microcontroller

P8xC557E8

---

### 7 FUNCTIONAL DESCRIPTION

The P8xC557E8 is a stand-alone high-performance microcontroller designed for use in real time applications such as instrumentation, industrial control, medium to high-end consumer applications and specific automotive control applications.

In addition to the 80C51 standard functions, the device provides a number of dedicated hardware functions for these applications.

The P8xC557E8 is a control-oriented CPU with on-chip program and Data Memory, but it cannot be extended with external Program Memory. It can access up to 64 kbytes of external Data Memory. For systems requiring extra capability, the P8xC557E8 can be expanded using standard memories and peripherals.

The functional description of the device is described in:

Chapter 8 "Memory organization"

Chapter 9 "I/O facilities"

Chapter 10 "Pulse Width Modulated outputs"

Chapter 11 "Analog-to-Digital Converter (ADC)"

Chapter 12 "Timers/counters"

Chapter 13 "Serial I/O ports"

Chapter 14 "Interrupt system"

Chapter 15 "Reduced power modes"

Chapter 16 "Oscillator circuits"

Chapter 17 "Reset circuitry".

## 8-bit microcontroller

## P8xC557E8

**8 MEMORY ORGANIZATION**

The Central Processing Unit (CPU) manipulates operands in three memory spaces; these are the 64 kbytes external Data Memory, 2048 bytes internal Data Memory (consisting of 256 bytes standard RAM and 1792 bytes AUX-RAM) and the 64 kbytes internal or 64 kbytes external Program Memory (see Fig.4).

**8.1 Program Memory**

The Program Memory of the P8xC557E8 consists of 64 kbytes ROM or 64 kbytes EPROM. If, during reset, the  $\overline{EA}$  pin was held HIGH, the P8xC557E8 always executes out of the internal Program Memory. If the  $\overline{EA}$  pin was held LOW during reset the P8xC557E8 fetches all instructions from the external Program Memory. The  $\overline{EA}$  input is latched during reset and is don't care after reset.

The internal Program Memory content is protected by setting a mask programmable security bit (ROM) or by the software programmable security bits (EPROM) respectively, i.e. it cannot be read out at any time by any test mode or by any instruction in the external Program Memory space. The MOVC instructions are the only ones which have access to program code in the internal or external Program Memory. The  $\overline{EA}$  input is latched during reset and is don't care after reset. This implementation prevents from reading internal program code by switching from external Program Memory to internal Program Memory during MOVC instruction or an instruction that handles immediate data. Table 2 lists the access to the internal and external Program Memory with MOVC instructions whether the security feature has been activated or not.

Due to the maximum size of the internal Program Memory, the MOVC instructions can always operate either in the internal or in the external Program Memory.

**Table 2** Memory access by the MOVC instruction  
For code protection of the P87C557E8 see Section 23.2.

MOVC INSTRUCTION	PROGRAM MEMORY ACCESS	
	INTERNAL	EXTERNAL
MOVC in internal Program Memory	YES	NO <sup>(1)</sup>
MOVC in external Program Memory	NO <sup>(1)</sup>	YES

**Note**

1. Not applicable due to 64 kbytes internal Program Memory.

**8.2 Internal Data Memory**

The internal Data Memory is divided into three physically separated parts: 256 bytes of RAM, 1792 bytes of AUX-RAM, and a 128 bytes Special Function Registers (SFRs) area. These parts can be addressed each in a different way as described in Sections 8.2.1 to 8.2.2 and Table 3.

**Table 3** Internal Data Memory map

MEMORY	LOCATION	ADDRESS MODE
RAM	0 to 127	Direct and indirect
	128 to 255	Indirect only
SFR	128 to 255	Direct only
AUX-RAM	0 to 1791	Indirect only with MOVX

**8.2.1 RAM**

- RAM 0 to 127 can be addressed directly and indirectly as in the 80C51. Address pointers are R0 and R1 of the selected register bank.
- RAM 128 to 255 can only be addressed indirectly. Address pointers are R0 and R1 of the selected register bank.

Four register banks, each 8 registers wide, occupy locations 0 through 31 in the lower RAM area. Only one of these banks may be enabled at a time. The next 16 bytes, locations 32 through 47, contain 128 directly addressable bit locations. The stack can be located anywhere in the internal 256 bytes RAM. The stack depth is only limited by the available internal RAM space of 256 bytes (see Fig.6). All registers except the Program Counter and the four register banks reside in the Special Function Register address space.

**8.2.2 SPECIAL FUNCTION REGISTERS**

The Special Function Registers can only be addressed directly in the address range from 128 to 255 (see Fig.7).

**8.2.3 AUX-RAM**

- AUX-RAM 0 to 1791 is indirectly addressable via page register (XRAMP) and MOVX-Ri instructions, unless it is disabled by setting ARD = 1 (see Fig.5). When executing from internal Program Memory, an access to AUX-RAM 0 to 1791 will not affect the ports P0, P2, P3.6 and P3.7.
- AUX-RAM 0 to 1791 is also indirectly addressable as external Data Memory locations 0 to 1791 via MOVX-Ri instructions, unless it is disabled by setting ARD = 1.

## 8-bit microcontroller

## P8xC557E8

An access to external Data Memory locations higher than 1791 will be performed with the MOVX @DPTR instructions in the same way as in the 80C51 structure, so with P0 and P2 as data/address bus and P3.6 and P3.7 as write and read timing signals.

Note that the external Data Memory cannot be accessed with R0 and R1 as address pointer if the AUX-RAM is enabled (ARD = 0, default).

## 8.2.4 AUX-RAM PAGE REGISTER (XRAMP)

The AUX-RAM Page Register is used to select one of seven 256-bytes pages of the internal 1792 bytes AUX-RAM for MOVX-accesses via R0 or R1. Its reset value is 'XXXX X000B'.

**Table 4** AUX-RAM Page Register (address FAH)

7	6	5	4	3	2	1	0
XRAMPx	XRAMPx	XRAMPx	XRAMPx	XRAMPx	XRAMP2	XRAMP1	XRAMP0

**Table 5** Description of XRAMP bits

BIT	SYMBOL	FUNCTION
7 to 3	XRAMPx	Reserved for future use. During read XRAMPx = undefined; a write operation must write logic 0s to these locations.
2 to 0	XRAMP2 to XRAMP0	AUX-RAM page select bits 2 to 0; see Table 6.

**Table 6** Memory locations for all possible MOVX-accesses

X = don't care.

ARD <sup>(1)</sup>	XRAMP2	XRAMP1	XRAMP0	MEMORY LOCATIONS
<b>MOVX @Ri,A and MOVX A,@Ri instructions access</b>				
0	0	0	0	AUX-RAM locations 0 to 255 (reset condition)
0	0	0	1	AUX-RAM locations 256 to 511
0	0	1	0	AUX-RAM locations 512 to 767
0	0	1	1	AUX-RAM locations 768 to 1023
0	1	0	0	AUX-RAM locations 1024 to 1279
0	1	0	1	AUX-RAM locations 1280 to 1535
0	1	1	0	AUX-RAM locations 1536 to 1791
0	1	1	1	No valid memory access; reserved for future use
1	X	X	X	External RAM locations 0 to 255
<b>MOVX @DPTR,A and MOVX A,@DPTR instructions access</b>				
0	X	X	X	AUX-RAM locations 0 to 1791 (reset condition); External RAM locations 1792 to 65535
1	X	X	X	External RAM locations 0 to 65535

**Note**

- ARD: AUX-RAM disable, is a bit in SFR PCON (bit PCON.6); see Section 15.5.

8-bit microcontroller

P8xC557E8

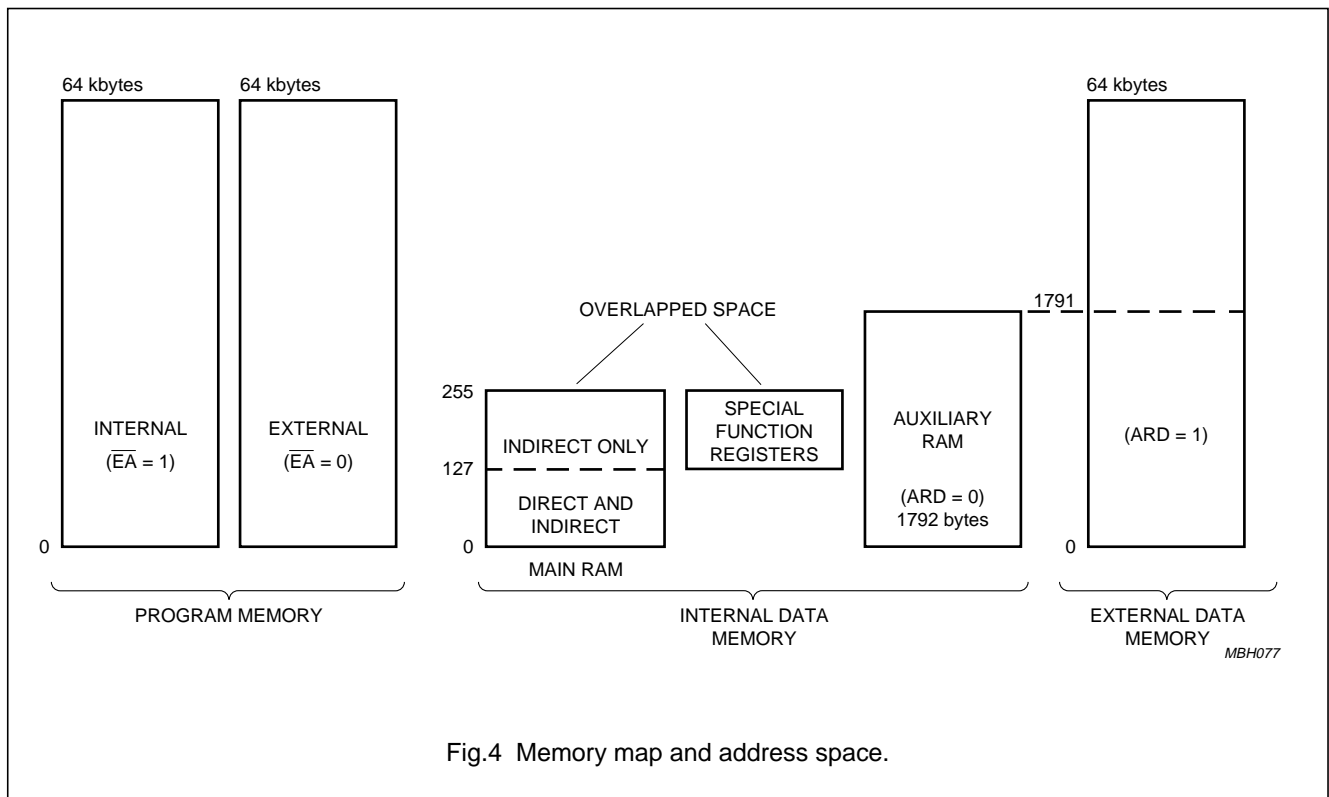

Fig.4 Memory map and address space.

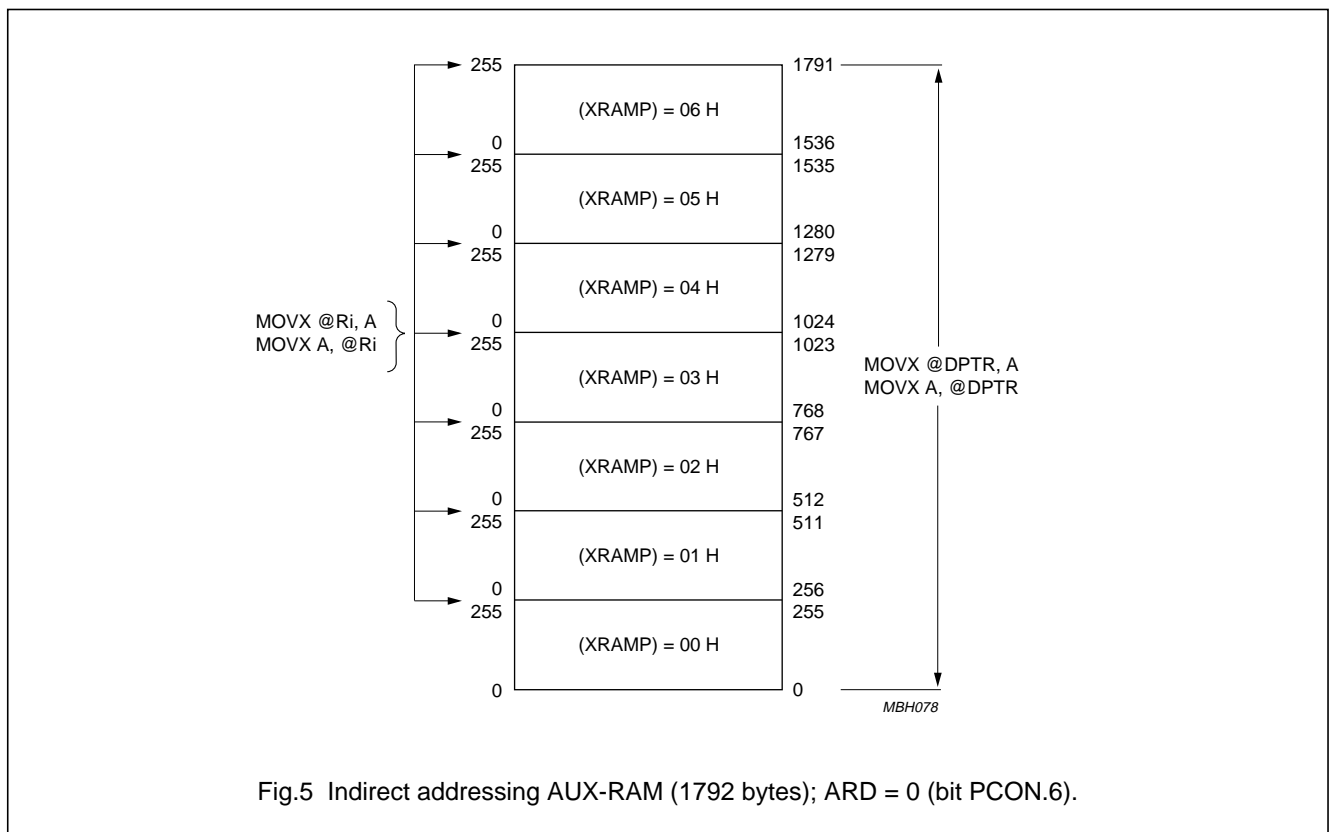

Fig.5 Indirect addressing AUX-RAM (1792 bytes); ARD = 0 (bit PCON.6).

# 8-bit microcontroller

# P8xC557E8

### 8.3 Addressing

The P8xC557E8 has five methods for addressing:

- Register
- Direct
- Register-Indirect
- Immediate
- Base-Register plus Index-Register-Indirect.

The first three methods can be used for addressing destination operands. Most instructions have a 'destination/source' field that specifies the data type, addressing methods and operands involved. For operations other than MOVs, the destination operand is also a source operand.

Access to memory addresses is as follows:

- Register in one of the four register banks through Register, Direct or Register-Indirect addressing.
- Internal RAM (2048 bytes) through Direct or Register-Indirect addressing.
  - Internal RAM: bytes 0 to 127; may be addressed directly/indirectly.
  - Internal RAM: bytes 128 to 255; share their address location with the SFRs and so may only be addressed indirectly as data RAM.
  - AUX-RAM: bytes 0 to 1791; can only be addressed indirectly via MOVX.
- Special Function Registers through direct addressing at address locations 128 to 255 (see Fig.7).
- External Data Memory through Register-Indirect addressing.
- Program Memory look-up tables through Base-Register plus Index-Register-Indirect addressing.

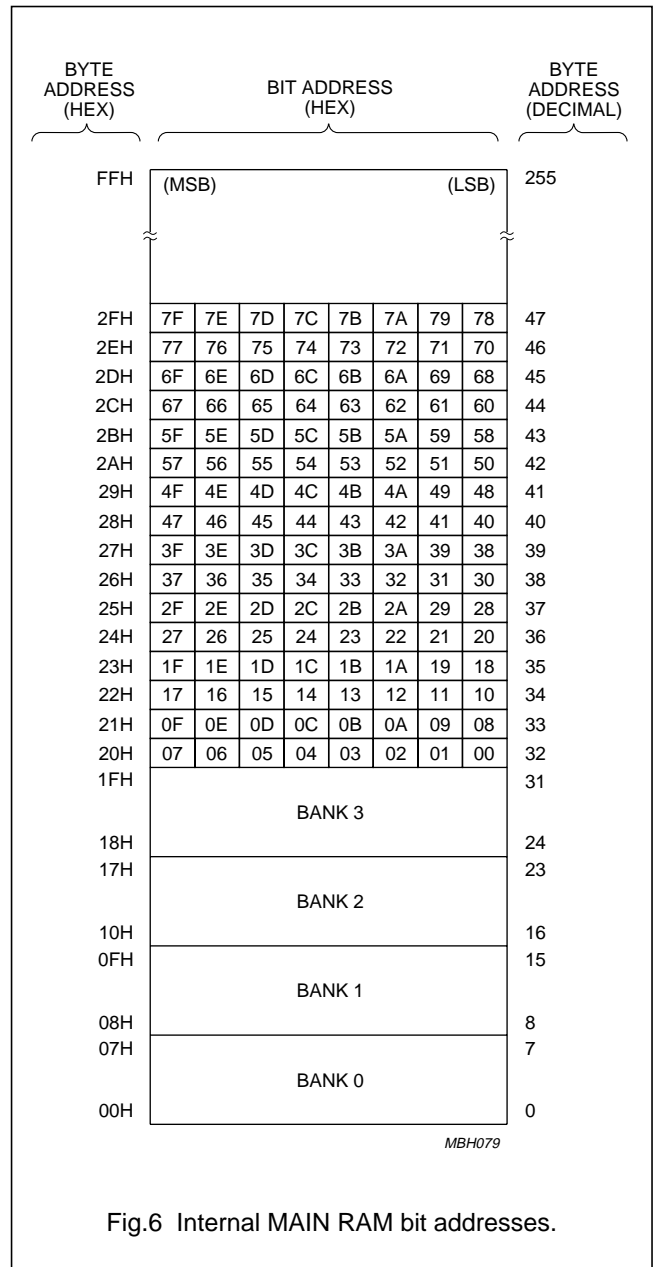

Fig.6 Internal MAIN RAM bit addresses.

8-bit microcontroller

P8xC557E8

BYTE ADDRESS (HEX)	BIT ADDRESS (HEX)								REGISTER (MNEMONIC)
FFH	(MSB) (LSB)								
	PT2	PCM2	PCM1	PCM0	PCT3	PCT2	PCT1	PCT0	
F8H	FF	FE	FD	FC	FB	FA	F9	F8	IP1
F0H	F7	F6	F5	F4	F3	F2	F1	F0	B
	ET2	ECM2	ECM1	ECM0	ECT3	ECT2	ECT1	ECT0	
F8H	EF	EE	ED	EC	EB	EA	E9	E8	IEN1
E0H	E7	E6	E5	E4	E3	E2	E1	E0	ACC
	CR2	ENS1	STA	STO	SI	AA	CR1	CR0	
D8H	DF	DE	DD	DC	DB	DA	D9	D8	S1CON
	CY	AC	F0	RS1	RS0	OV	F1	P	
D0H	D7	D6	D5	D4	D3	D2	D1	D0	PSW
	T2OV	CMI2	CMI1	CMI0	CTI3	CTI2	CTI1	CTI0	
C8H	CF	CE	CD	CC	CB	CA	C9	C8	TM2IR
C0H	C7	C6	C5	C4	C3	C2	C1	C0	P4
	-	PAD	PS1	PS0	PT1	PX1	PT0	PX0	
B8H	BF	BE	BD	BC	BB	BA	B9	B8	IP0
B0H	B7	B6	B5	B4	B3	B2	B1	B0	P3
	EA	EAD	ES1	ES0	ET1	EX1	ET0	EX0	
A8H	AF	AE	AD	AC	AB	AA	A9	A8	IEN0
A0H	A7	A6	A5	A4	A3	A2	A1	A0	P2
	SM0	SM1	SM2	REN	TB8	RB8	TI	RI	
98H	9F	9E	9D	9C	9B	9A	99	98	S0CON
90H	97	96	95	94	93	92	91	90	P1
	TF1	TR1	TF0	TR0	IE1	IT1	IE0	IT0	
88H	8F	8E	8D	8C	8B	8A	89	88	TCON
80H	87	86	85	84	83	82	81	80	P0

MBH456

Fig.7 Special Function Registers bit addresses.

8-bit microcontroller

P8xC557E8

9 I/O FACILITIES

The P8xC557E8 has six 8-bit ports. Ports 0 to 3 are the same as in the 80C51, with the exception of the additional functions of Port 1. The parallel I/O function of Port 4 is equal to that of Ports 1, 2 and 3. All ports are bidirectional with the exception of Port 5 which is only a parallel input port.

Ports 0, 1, 2, 3, 4 and 5 perform the following alternative functions:

Port 0 Provides the multiplexed low-order address and data bus used for expanding the P8xC557E8 with standard memories and peripherals.

Port 1 Is used for a number of special functions:

- 4 capture inputs (or external interrupt request inputs if capture information is not utilized)
- external counter input
- external counter reset input.

Port 2 Provides the high-order address bus when the P8xC557E8 is expanded with external Data Memory and / or the P8xC557E8 executes from external Program Memory.

Port 3 Pins can be configured individually to provide:

- External interrupt request inputs
- Counter inputs
- Receiver input and transmitter output of serial port SIO 0 (UART)
- Control signals to read and write external Data Memory.

Port 4 Can be configured to provide signals indicating a match between timer/counter T2 and its compare registers.

Port 5 May be used in conjunction with the ADC interface. Unused analog inputs can be used as digital inputs. As Port 5 lines may be used as inputs to the ADC, these digital inputs have an inherent hysteresis to prevent the input logic from drawing too much current from the power lines when driven by analog signals. Channel-to-channel crosstalk should be taken into consideration when both digital and analog signals are simultaneously input to Port 5 (see Chapter 21).

A pin of which the alternative function is not used may be used as normal bidirectional I/O. The generation or use of a Port 1, Port 3 or Port 4 pin as an alternative function is carried out automatically by the P8xC557E8 provided the associated Special Function Register bit is set HIGH.

The SDA and SCL lines serve the serial port SI01 (I<sup>2</sup>C-bus). Because the I<sup>2</sup>C-bus may be active while the device is disconnected from V<sub>DD</sub>, these pins are provided with open-drain drivers.

Figure 8 shows the pull-up arrangements of Ports 1 to 4; Transistor 'p1' is turned on for 2 oscillator periods after Q makes a HIGH-to-LOW transition. During this time, 'p1' also turns on 'p3' through the inverter to form an additional pull-up.

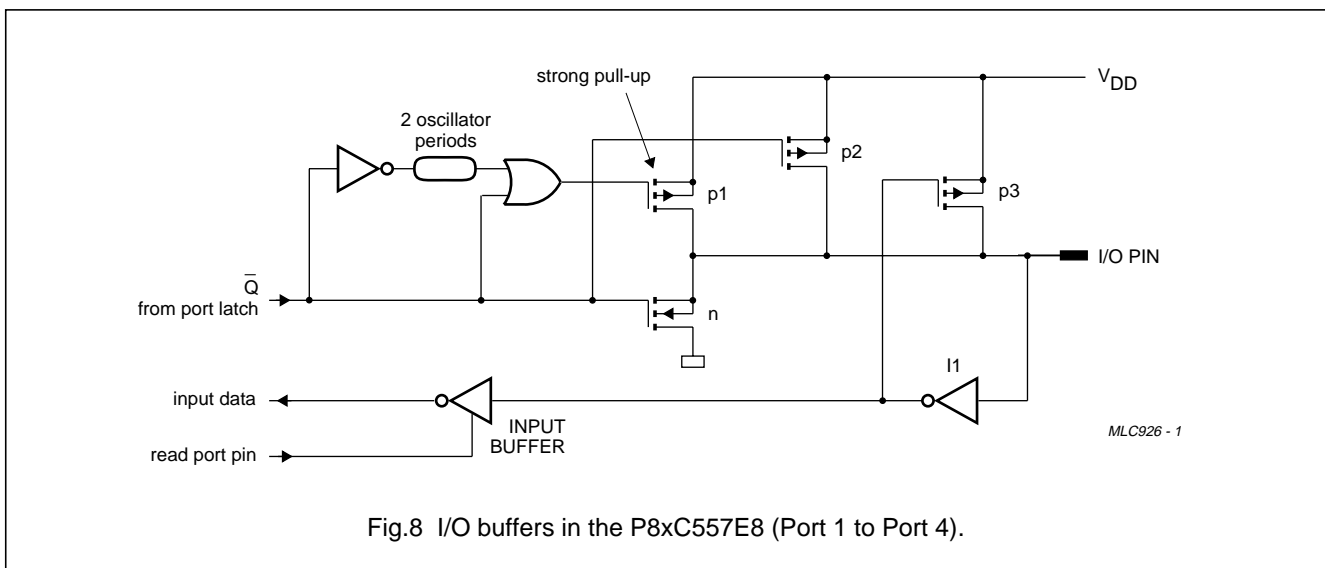

Fig.8 I/O buffers in the P8xC557E8 (Port 1 to Port 4).



8-bit microcontroller

P8xC557E8

10 PULSE WIDTH MODULATED OUTPUTS

The P8xC557E8 contains two Pulse Width Modulated (PWM) output channels (see Fig.9). These channels generate pulses of programmable length and interval. The repetition frequency is defined by an 8-bit prescaler PWMP, which supplies the clock for the counter. The prescaler and counter are common to both PWM channels. The 8-bit counter counts modulo 255, i.e., from 0 to 254 inclusive. The value of the 8-bit counter is compared to the contents of two registers: PWM0 and PWM1.

Provided the contents of either of these registers is greater than the counter value, the corresponding PWM0 or PWM1 output is set LOW. If the contents of these registers are equal to, or less than the counter value, the output will be HIGH. The pulse-width-ratio is therefore defined by the contents of the registers PWM0 and PWM1. The pulse-width-ratio is in the range of  $0/255$  to  $255/255$  and may be programmed in increments of  $1/255$ .

Buffered PWM outputs may be used to drive DC motors. The rotation speed of the motor would be proportional to the contents of PWMn. The PWM outputs may also be configured as a dual DAC.

In this application, the PWM outputs must be integrated using conventional operational amplifier circuitry. If the resulting output voltages have to be accurate, external buffers with their own analog supply should be used to buffer the PWM outputs before they are integrated.

The repetition frequency  $f_{PWM}$ , at the  $\overline{PWMn}$  outputs is

$$f_{PWM} = \frac{f_{CLK}}{2 \times (PWMP + 1) \times 255}$$

This gives a repetition frequency range of 123 Hz to 31.4 kHz (at  $f_{clk} = 16$  MHz). By loading the PWM registers with either 00H or FFH, the PWM channels will output a constant HIGH or LOW level, respectively. Since the 8-bit counter counts modulo 255, it can never actually reach the value of the PWM registers when they are loaded with FFH.

When a compare register (PWM0 or PWM1) is loaded with a new value, the associated output is updated immediately. It does not have to wait until the end of the current counter period. Both  $\overline{PWMn}$  output pins are driven by push-pull drivers. These pins are not used for any other purpose.

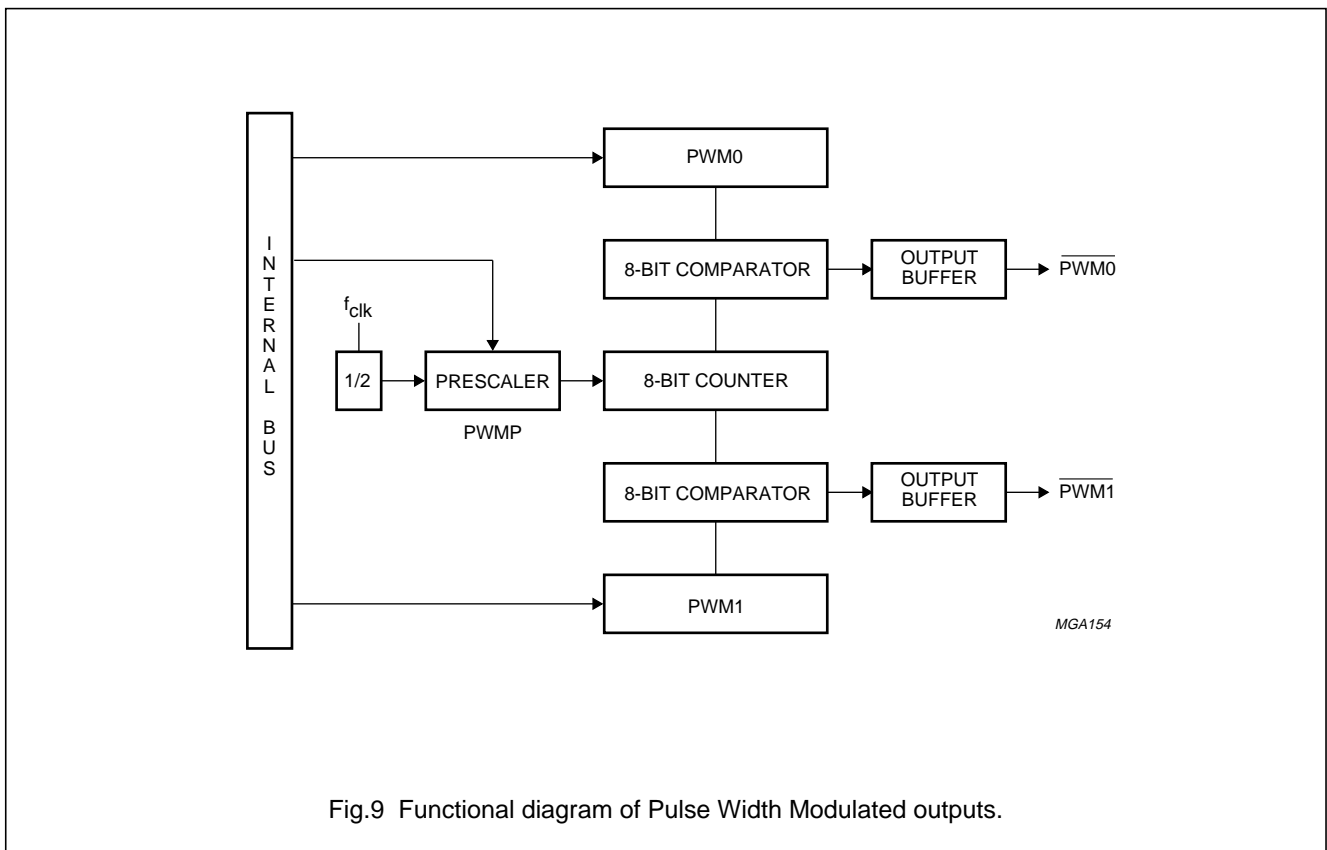

Fig.9 Functional diagram of Pulse Width Modulated outputs.

8-bit microcontroller

P8xC557E8

10.1 Prescaler Frequency Control Register (PWMP)

Reading PWMP gives the current reload value. The actual count of the prescaler cannot be read.

Table 7 Prescaler Frequency Control Register (address FEH)

<b>7</b>	<b>6</b>	<b>5</b>	<b>4</b>	<b>3</b>	<b>2</b>	<b>1</b>	<b>0</b>
PWMP.7	PWMP.6	PWMP.5	PWMP.4	PWMP.3	PWMP.2	PWMP.1	PWMP.0

Table 8 Description of PWMP bits

BIT	SYMBOL	DESCRIPTION
7 to 0	PWMP.7 to PWMP.0	<b>Prescaler division factor.</b> The Prescaler division factor = (PWMP) + 1.

10.2 Pulse Width Register 0 (PWM0)

Table 9 Pulse width register (address FCH)

<b>7</b>	<b>6</b>	<b>5</b>	<b>4</b>	<b>3</b>	<b>2</b>	<b>1</b>	<b>0</b>
PWM0.7	PWM0.6	PWM0.5	PWM0.4	PWM0.3	PWM0.2	PWM0.1	PWM0.0

Table 10 Description of PWM0 bits

BIT	SYMBOL	DESCRIPTION
7 to 0	PWM0.7 to PWM0.0	<b>Pulse width ratio.</b> LOW/HIGH ratio of $\overline{\text{PWM0}}$ signals = $\frac{(\text{PWM0})}{255 - (\text{PWM0})}$

10.3 Pulse Width Register 1 (PWM1)

Table 11 Pulse width register (address FDH)

<b>7</b>	<b>6</b>	<b>5</b>	<b>4</b>	<b>3</b>	<b>2</b>	<b>1</b>	<b>0</b>
PWM1.7	PWM1.6	PWM1.5	PWM1.4	PWM1.3	PWM1.2	PWM1.1	PWM1.0

Table 12 Description of PWM1 bits

BIT	SYMBOL	DESCRIPTION
7 to 0	PWM1.7 to PWM1.0	<b>Pulse width ratio.</b> LOW/HIGH ratio of $\overline{\text{PWM1}}$ signals = $\frac{(\text{PWM1})}{255 - (\text{PWM1})}$

## 8-bit microcontroller

## P8xC557E8

**11 ANALOG-TO-DIGITAL CONVERTER (ADC)****11.1 ADC features**

- 10-bit resolution
- 8 multiplexed analog inputs
- Programmable autoscan of the analog inputs
- Bit oriented 8-bit scan-select register to select analog inputs
- Continuous scan or one time scan configurable from 1 to 8 analog inputs
- Start of a conversion by software or with an external signal
- Eight 10-bit buffer registers, one register for each analog input channel
- Interrupt request after one channel scan loop
- Programmable prescaler (dividing by 2, 4, 6, 8) to adapt to different system clock frequencies
- Conversion time for one analog-to-digital conversion: 15 to 50  $\mu$ s
- Differential non-linearity ( $DL_e$ ):  $\pm 1$  LSB
- Integral non-linearity ( $IL_e$ ):  $\pm 2$  LSB
- Offset error ( $OS_e$ ):  $\pm 2$  LSB
- Gain error ( $G_e$ ):  $\pm 4\%$
- Absolute voltage error ( $A_e$ ): 3 LSB
- Channel-to-channel matching ( $M_{ctc}$ ):  $\pm 1$  LSB
- Crosstalk between analog inputs ( $C_i$ ):  $< 60$  dB at 100 kHz
- Monotonic and no missing codes
- Separated analog ( $V_{DDA}$ ,  $V_{SSA}$ ) and digital ( $V_{DD}$ ,  $V_{SS}$ ) supply voltages
- Reference voltage at two special pins:  $V_{ref(n)(A)}$  and  $V_{ref(p)(A)}$ .

For information on the ADC characteristics, refer to Chapter 21.

**11.2 ADC functional description**

The P8xC557E8 has a 10-bit successive approximation ADC with 8 multiplexed analog input channels, comprising a high input impedance comparator, DAC (built with 1024 series resistors and analog switches), registers and control logic. Input voltage range is from  $V_{ref(n)(A)}$  (typical 0 V) to  $V_{ref(p)(A)}$  (typical +5 V).

Each of the set of 8 buffer registers (10-bit wide) store the conversion results of the proper analog input channel.

Eleven Special Function Registers (SFRs) perform the user software interface to the ADC; see Table 14 for an overview of the ADC SFRs. In order to have a minimum of ADC service overhead in the microcontroller program, the ADC is able to operate autonomously within its user configurable autoscan function.

Figure 10 shows the functional diagram of the ADC.

**11.3 ADC timing**

A programmable prescaler is controlled by the user selectable bits ADPR1 and ADPR0 in SFR ADCON to adapt the conversion time for different microcontroller clock frequencies.

Table 13 shows conversion times ( $t_{ADC}$ ) for one analog-to-digital conversion at some convenient system clock frequencies ( $f_{clk}$ ) and ADC programmable prescaler divisors: **m**.

Conversion time  $t_{ADC} = (6 \times m + 1)$  machine cycles.

A conversion time  $t_{ADC}$  consists of one sample time period (which equals two bit conversion times), 10 bit conversion time periods and one machine cycle to store the result. After result storage an extra initializing time period follows to select the next analog input channel (according to the contents of SFR ADPSS), before the input signal is sampled. Thus the time period between two adjacent conversions within an autoscan loop is larger than the pure time  $t_{ADC}$ . This autoscan cycle time is  $(7 \times m)$  machine cycles.

At the start of an autoscan conversion the time between writing to SFR ADCON and the first analog input signal sampling depends on the current prescaler value (**m**) and the relative time offset between this write operation and the internal (divided) ADC clock. This gives a variation range for the analog-to-digital conversion start time of  $(\frac{1}{2} \times m)$  machine cycles.

**Table 13** Conversion time configuration examples

m	$t_{ADC}$ ( $\mu$ s) at $f_{CLK}$ :			
	6 MHz	8 MHz	12 MHz	16 MHz
2	26.00	19.50	13.00 <sup>(1)</sup>	9.75 <sup>(1)</sup>
4	50.00	37.50	25.00	18.75
6	74.00 <sup>(1)</sup>	55.50 <sup>(1)</sup>	37.00	27.75
8	98.00 <sup>(1)</sup>	73.50 <sup>(1)</sup>	49.00	36.75

**Note**

1. Prohibited  $t_{ADC}$  values; for  $t_{ADC}$  outside the limits of  $15 \mu s \leq t_{ADC} \leq 50 \mu s$ , the specified ADC characteristics are not guaranteed.

8-bit microcontroller

P8xC557E8

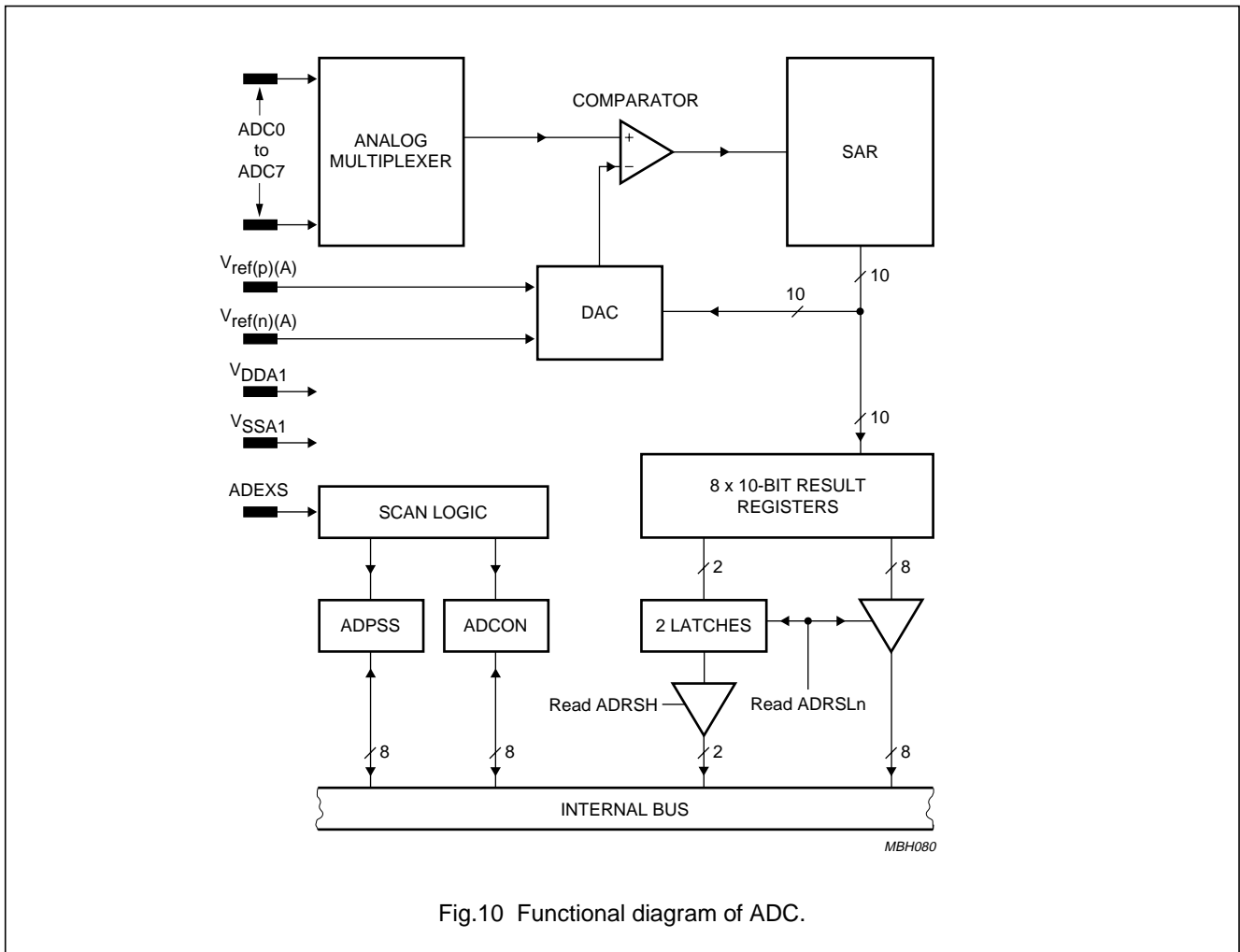

Fig.10 Functional diagram of ADC.

11.4 ADC configuration and operation

Every analog-to-digital conversion is an autoscan conversion. The two user selectable general operation modes are continuous scan and one-time scan mode.

The desired analog input port channel(s) for conversion is(are) selected by programming analog-to-digital input port scan-select bits in SFR ADPSS. An analog input channel is included in the autoscan loop if the corresponding bit in SFR ADPSS is logic 1, a channel is skipped if the corresponding bit in SFR ADPSS is logic 0.

An autoscan is always started according to the lowest bit position of SFR ADPSS that contains a logic 1.

An autoscan conversion is started by setting the flag ADSST in register ADCON either by software or by an external start signal at input pin ADEXS, if enabled.

Either no edge (external start totally disabled), a rising edge or/and a falling edge of ADEXS is selectable for external conversion start by the bits ADSRE and ADSFE in register ADCON.

After completion of an analog-to-digital conversion the 10-bit result is stored in the corresponding 10-bit buffer register. Then the next analog input is selected according to the next higher set bit position in ADPSS, converted and stored, and so on.

When the result of the last conversion of this autoscan loop is stored, the ADC interrupt flag ADINT (SFR ADCON), is set. It is not cleared by interrupt hardware - it must be cleared by software.

## 8-bit microcontroller

## P8xC557E8

In continuous scan mode (ADCSA = 1; ADCON.2) the ADC start and status flag ADSST (ADCON.3) retains the set state and the autoscan loop restarts from the beginning. In one-time scan mode (ADCSA = 0) conversions stop after the last selected analog input was converted, ADINT (ADCON.4) is set and ADSST is cleared automatically.

ADSST cannot be set (neither externally nor by software) as long as ADINT = 1, i.e. as long as ADINT is set, a new conversion start - by setting flag ADSST - is inhibited; actually it is only delayed until ADINT is cleared. If a logic 1 is written to ADSST while ADINT = 1, this new value is internally latched and preserved, not setting ADSST until ADINT = 0. In this state, a read of SFR ADCON will display ADSST = 0, because always the effective ADC status is read.

Note that under software control the analog inputs can also be converted in arbitrary order, when one-time scan mode is selected and in SFR ADPSS only one bit is set at a time. In this case ADINT is set and ADSST is cleared after every conversion.

### 11.5 ADC during Idle and Power-down mode

The analog-to-digital converter is active only when the microcontroller is in normal operating mode. If the Idle or Power-down mode is activated, then the ADC is switched off and put into a power saving idle state - a conversion in progress is aborted, a previously set ADSST flag is cleared and the internal clock is halted. The conversion result registers are not affected.

The interrupt flag ADINT will not be set by activation of Idle or Power-down mode. A previously set flag ADINT will not be cleared by the hardware. (Note: ADINT cannot be cleared by hardware at all, except for a reset - it must be cleared by the user software.)

After a wake-up from Idle or Power-down mode a set flag ADINT indicates that at least one autoscan loop was finished completely before the microcontroller was put into the respective power reduction mode and it indicates that the stored result data may be fetched now - if desired.

For further information on Idle and Power-down modes, refer to Chapter 15.

### 11.6 ADC resolution and characteristics

The ADC system has its own analog supply pins  $V_{DDA1}$  and  $V_{SSA1}$ . It is referenced by two special reference voltage input pins sourcing the resistance ladder of the DAC:  $V_{ref(p)(A)}$  and  $V_{ref(n)(A)}$ . The voltage between  $V_{ref(p)(A)}$  and  $V_{ref(n)(A)}$  defines the full-scale range. Due to the 10-bit resolution the full scale range is divided into 1024 unit steps.

The unit step voltage is 1 LSB, which is typically 5 mV ( $V_{ref(p)(A)} = 5.12 \text{ V}$ ,  $V_{ref(n)(A)} = 0 \text{ V} = V_{SSA1}$ ).

The DAC's resistance ladder has 1023 equally spaced taps, separated by a unit resistance 'R'.

The first tap is located  $0.5 \times R$  above  $V_{ref(n)(A)}$ , the last tap is located  $1.5 \times R$  below  $V_{ref(p)(A)}$ . This results in a total ladder resistance of  $1024 \times R$ . This structure ensures that the DAC is monotonic and results in a symmetrical quantization error. For input voltages between:

- $V_{ref(n)(A)}$  and  $[V_{ref(n)(A)} + \frac{1}{2} \times \text{LSB}]$  the 10-bit conversion result code will be 0000000000B (= 000H or 0D)
- $[V_{ref(p)(A)} - \frac{3}{2} \times \text{LSB}]$  and  $V_{ref(p)(A)}$  the 10-bit conversion result code will be 1111111111B (= 3FFH or 1023D).

The result code corresponding to an analog input voltage ( $V_{in(A)}$ ) can be calculated from the formula:

$$\text{Result code} = 1024 \times \frac{V_{in(A)} - V_{ref(n)(A)}}{V_{ref(p)(A)} - V_{ref(n)(A)}}$$

The analog input voltage should be stable when it is sampled for conversion. At any times the input voltage slew rate must be less than 10 V/ms (5 V conversion range) in order to prevent an undefined result. This maximum input voltage slew rate can be ensured by an RC low pass filter with  $R = 2.2 \text{ k}\Omega$  and  $C = 100 \text{ nF}$ . The capacitor between analog input pin and analog ground pin shall be placed close to the pins in order to have maximum effect in minimizing input noise coupling.

### 11.7 ADC after reset

After a reset of the microcontroller the ADCON and ADPSS registers are initialized to zero. Registers ADRSLn and ADRSH are not initialized by a reset.

## 8-bit microcontroller

## P8xC557E8

## 11.8 ADC Special Function Registers

**Table 14** ADC Special Function Registers overview

The SFRs are not bit addressable. For more information on Special Function Registers refer to Section 8.2.

ADDRESS	NAME	R/W	RESET VALUE	DESCRIPTION
86H	ADRSL0	R	–	<b>ADC Result Registers Low Byte: ADRSL0 to ADRSL7</b> ; The read value after reset is indeterminate. Their data are not affected by chip reset.
96H	ADRSL1			
A6H	ADRSL2			
B6H	ADRSL3			
C6H	ADRSL4			
D6H	ADRSL5			
E6H	ADRSL6			
F6H	ADRSL7			
F7H	ADRSH	R	00H	<b>ADC Result Register High Bits</b> : one common result SFR for the upper 2 result bits.
E7H	ADPSS	R/W	00H	<b>ADC Input Port Scan-Select Register</b> . Contains control bits to select the analog input channel(s) to be scanned for analog-to-digital conversion.
D7H	ADCON	R/W	00H	<b>ADC Control Register</b> . Contains control and status bits for the analog-to-digital converter peripheral block.
C7H	P5	R	–	<b>Digital Input Port Register</b> ; shared with analog inputs. P5 is not affected by chip reset.

## 11.8.1 ADC RESULT REGISTERS

The binary result code of the analog-to-digital conversions is accessed by the ADC Result Registers:

- ADRSL<sub>n</sub> (ADRSL0 to ADRSL7); eight input channel related conversion result SFRs for the 8 result lower bytes. Each of ADRSL<sub>n</sub> is associated with the indexed analog input channel ADC<sub>n</sub> (ADC0/P5.0 to ADC7/P5.7).
- ADRSH for the ADC; one general SFR for the 2 result upper bits (bit 9 and 8).

During read (by software) of the ADRSL<sub>n</sub> register, simultaneously the two highest bits of the 10-bit conversion result are copied into the two latches, ADRSH.0 and ADRSH.1 (SFR ADRSH) preserving them until the next read of any ADRSL<sub>n</sub> register. Thus to ensure that the 10-bit result of the same single analog-to-digital conversion is captured, first read the ADRSL<sub>n</sub> register and then the ADRSH register.

**Table 15** ADC Result Register Low Byte; ADRSL<sub>n</sub>; n = 0 to 7 (address see 86H to F6H)

7	6	5	4	3	2	1	0
ADRSn.7	ADRSn.6	ADRSn.5	ADRSn.4	ADRSn.3	ADRSn.2	ADRSn.1	ADRSn.0

**Table 16** Description of ADRSL<sub>n</sub> bits

BIT	SYMBOL	DESCRIPTION
7 to 0	ADRSn.7 to ADRSn.0	ADC result lower byte.

## 8-bit microcontroller

## P8xC557E8

**Table 17** ADC Result Register High Bits; ADRSH (address F7H)

7	6	5	4	3	2	1	0
0	0	0	0	0	0	ADRSn.9	ADRSn.8

**Table 18** Description of ADRSH bits

BIT	SYMBOL	DESCRIPTION
7 to 2	–	The upper 6 bits ADRSH.2 to ADRSH.7 are always read as a logic 0.
1 to 0	ADRSn.9 to ADRSn.8	ADC result upper 2 bits.

## 11.8.2 ADC INPUT PORT SCAN-SELECT REGISTER (ADPSS)

**Table 19** ADC Input Port Scan-Select Register (address E7H)

7	6	5	4	3	2	1	0
ADPSS7	ADPSS6	ADPSS5	ADPSS4	ADPSS3	ADPSS2	ADPSS1	ADPSS0

**Table 20** Description of ADPSS bits

BIT	SYMBOL	DESCRIPTION
7 to 0	ADPSS7 to ADPSS0	Control bits to select the analog input channel(s) to be scanned for analog-to-digital conversion. If all bits ADPSS0 to ADPSS7 = 0, then no conversion can be started. If ADPSS is written while an analog-to-digital conversion is in progress (ADSST = 1; ADCON.3) then the autoscan loop with the previous selected analog inputs is completed first. The next autoscan loop is performed with the new selected analog inputs. For each individual bit position ADPSSn (n = 0 to 7): <ul style="list-style-type: none"> <li>• If ADPSSn = 0, then the corresponding analog input is skipped in the autoscan loop</li> <li>• If ADPSSn = 1, then the corresponding analog input is included in the autoscan loop.</li> </ul>

## 11.8.3 ADC CONTROL REGISTER (ADCON)

**Table 21** ADC Control Register (address D7H)

7	6	5	4	3	2	1	0
ADPR1	ADPR0	ADPOS	ADINT	ADSST	ADCSA	ADSRE	ADSFE

**Table 22** Description of ADCON bits

BIT	SYMBOL	DESCRIPTION
7	ADPR1	These two bits determine the value of the prescaler divisor (m); see Table 23.
6	ADPR0	
5	ADPOS	ADPOS is reserved for future use. Must be a logic 0 if ADCON is written.
4	ADINT	<b>ADC interrupt.</b> This flag is set when all selected analog inputs are converted (both in continuous scan and in one-time scan mode). An interrupt is invoked if this interrupt flag is enabled. ADINT must be cleared by software. It cannot be set by software.

## 8-bit microcontroller

## P8xC557E8

BIT	SYMBOL	DESCRIPTION
3	ADSST	<b>ADC start and status.</b> Setting this bit by software or by hardware (via ADEXS input) starts the analog-to-digital conversion of the selected analog inputs. ADSST stays a logic 1 in continuous scan mode. In one-time scan mode, ADSST is cleared by hardware when the last selected analog input channel has been converted. As long as ADSST = 1, new start commands to the ADC-block are ignored. An analog-to-digital conversion in progress is aborted if ADSST is cleared by software.
2	ADCSA	ADCSA = 1 results in a continuous scan of the selected analog inputs after a start of an analog-to-digital conversion. ADCSA = 0 results in an one-time scan of the selected analog inputs after a start of an analog-to-digital conversion.
1	ADSRE	If ADSRE = 1, then a rising edge at input ADEXS will start the analog-to-digital conversion and generate a capture signal. If ADSRE = 0, then a rising edge at input ADEXS has no effect.
0	ADSFE	If ADSFE = 1, then a falling edge at input ADEXS will start the analog-to-digital conversion and generate a capture signal. If ADSFE = 0, then a falling edge at input ADEXS has no effect.

**Table 23** Prescaler selection

ADPR1	ADPR0	PRESCALER DIVISOR (m)
0	0	2 (default by reset)
0	1	4
1	0	6
1	1	8

## 11.8.4 DIGITAL INPUT PORT REGISTER (P5)

Digital Input Port Register (P5) is shared with analog inputs. P5 is not affected by chip reset. SFR P5 always represents the binary value of the logic level at input pins P5.0/ADC0 to P5.7/ADC7. Reading P5 does not affect analog-to-digital conversions. But it is recommended to use the digital input port function of the hardware Port 5 only as an alternative to analog input voltage conversions. Simultaneous mixed operation is discouraged to guarantee a reliable and accurate ADC result. For more information on P5 refer to Chapter 9.

**Table 24** Digital Input Port Register (address C7H)

7	6	5	4	3	2	1	0
P5.7	P5.6	P5.5	P5.4	P5.3	P5.2	P5.1	P5.0

**Table 25** Description of P5 bits

BIT	SYMBOL	DESCRIPTION
7 to 0	P5.7 to P5.0	Binary value of the logic level at input pins P5.0/ADC0 to P5.7/ADC.7.



## 8-bit microcontroller

## P8xC557E8

**12 TIMERS/COUNTERS**

The P8xC557E8 contains,

- Three 16-bit timer/event counters: Timer 0, Timer 1 and Timer T2
- One 8-bit timer, T3.

**12.1 Timer 0 and Timer 1**

Timer 0 and Timer 1 may be programmed to carry out the following functions:

- Measure time intervals and pulse durations
- Count events
- Generate interrupt requests.

Timers 0 and 1 each have a control bit in SFR TMOD that selects the timer or counter function of the corresponding timer.

In the timer function, the register is incremented every machine cycle. Thus, one can think of it as counting machine cycles. Since a machine cycle consists of 12 oscillator periods, the count rate is  $\frac{1}{12} \times$  the oscillator frequency.

In the counter function, the register is incremented in response to a HIGH-to-LOW transition at the corresponding external input pin, T0 or T1. In this function, the external input is sampled during S5P2 of every machine cycle. When the samples show a HIGH in one cycle and a LOW in the next cycle, the counter is incremented. Thus, it takes two machine cycles (24 oscillator periods) to recognize a HIGH-to-LOW transition. There are no restrictions on the duty cycle of the external input signal. To ensure that a given level is sampled at least once before it changes, it should be held for at least one full machine cycle.

Timer 0 and Timer 1 can be programmed independently to operate in one of four modes:

- Mode 0 8-bit timer or 8-bit counter each with divide-by-32 prescaler.
- Mode 1 16-bit time-interval or event counter.
- Mode 2 8-bit time-interval or event counter with automatic reload upon overflow.
- Mode 3 Timer 0: one 8-bit time-interval or event counter and one 8-bit time-interval counter.  
Timer 1: stopped.

When Timer 0 is in Mode 3, Timer 1 can be programmed to operate in Modes 0, 1 or 2 but cannot set an interrupt request flag or generate an interrupt. However, the overflow from Timer 1 can be used to pulse the serial port baud rate generator. With a 16 MHz crystal, the counting frequency of these timers/counters is as follows:

- In the timer function, the timer is incremented at a frequency of 1.33 MHz ( $\frac{1}{12} \times$  the system clock frequency)
- When programmed for external inputs: 0 to 660 kHz ( $\frac{1}{24} \times$  the system clock frequency).

Both internal and external inputs can be gated to the counter by a second external source for directly measuring pulse durations. When configured as a counter, the register is incremented on every falling edge on the corresponding input pin T0 or T1. The earliest moment, the incremented register value can be read is during the second machine cycle following the machine cycle within which the incrementing pulse occurred.

The counters are started and stopped under software control. Each one sets its interrupt request flag when it overflows from all HIGHS to all LOWs (or automatic reload value), with the exception of Mode 3 as previously described.

## 8-bit microcontroller

## P8xC557E8

## 12.1.1 TIMER/COUNTER MODE CONTROL REGISTER (TMOD)

**Table 26** Timer/Counter Mode Control Register (address 89H)

7	6	5	4	3	2	1	0
GATE	C/T	M1	M0	GATE	C/T	M1	M0

**Table 27** Description of TMOD bits for Timer 1 and Timer 0

Timer 0: bit TMOD.0 to TMOD.3; Timer 1: bit TMOD.4 to TMOD.7; n = 0, 1.

BIT	SYMBOL	DESCRIPTION
7 and 3	GATE	<b>Gating control.</b> When set Timer/counter 'n' is enabled only while $\overline{\text{INTn}}$ pin is HIGH and control bit TRn (TR1 or TR0) is set. When cleared Timer 'n' is enabled whenever TRn control bit is set.
6 and 2	C/T	<b>Timer or Counter Selector.</b> Cleared for Timer operation; input from internal system clock. Set for Counter operation; input from pin Tn (T1 or T0).
5 and 1	M1	<b>Timer 0, Timer 1 mode select;</b> see Table 28.
4 and 0	M0	

**Table 28** Timer 0, Timer 1 mode select

M1	M0	OPERATING
0	0	Timer TL0/TL1 serves as 5-bit prescaler.
0	1	16-bit Timer/Counter TH0/TH1 and TL0/TL1 are cascaded; there is no prescaler.
1	0	8-bit auto-reload Timer/Counter TH0/TH1 holds a value which is to be reloaded into TL0/TL1 each time it overflows.
1	1	Timer 0: TL0 is an 8-bit Timer/Counter controlled by the standard Timer 0 control bits. TH0 is an 8-bit timer only controlled by Timer 1 control bits.
1	1	Timer 1: Timer/Counter 1 stopped.

## 12.1.2 TIMER/COUNTER CONTROL REGISTER (TCON)

**Table 29** Timer/Counter Control Register (address 88H)

7	6	5	4	3	2	1	0
TF1	TR1	TF0	TR0	IE1	IT1	IE0	IT0

**Table 30** Description of TCON bits

BIT	SYMBOL	DESCRIPTION
7 and 5	TF1 and TF0	<b>Timer 1 and Timer 0 overflow flag.</b> Set by hardware on Timer/Counter overflow. Cleared by hardware when processor vectors to interrupt routine.
6 and 4	TR1 and TR0	<b>Timer 1 and Timer 0 run control bit.</b> Set/cleared by software to turn Timer/Counter on/off.
3 and 1	IE1 and IE0	<b>Interrupt 1 and Interrupt 0 edge flag.</b> Set by hardware when external interrupt edge detected. Cleared when interrupt processed.
2 and 0	IT1 and IT0	<b>Interrupt 1 and Interrupt 0 type control bit.</b> Set/cleared by software to specify falling edge/low level triggered external interrupts.

## 8-bit microcontroller

## P8xC557E8

**12.2 Timer T2**

Timer T2 is a 16-bit timer/counter which has capture and compare facilities. The operational diagram is shown in Figure 11.

The 16 bit timer/counter is clocked via a prescaler with a programmable division factor of 1, 2, 4 or 8. The input of the prescaler is clocked with  $\frac{1}{12}$  of the clock frequency, or by an external source connected to the T2 input, or it is switched off. The maximum repetition rate of the external clock source is  $\frac{1}{12} \times f_{clk}$ , twice that of Timer 0 and Timer 1. The prescaler is incremented on a rising edge. It is cleared if its division factor or its input source is changed, or if the timer/counter is reset (see in Table 31). T2 is readable 'on the fly', without any extra read latches; this means that software precautions have to be taken against misinterpretation at overflow from least to most significant byte while T2 is being read. T2 is not loadable and is reset by the RST signal or at the positive edge of the input signal RT2, if enabled. In the Idle or Power-down mode the timer/counter and prescaler are reset and halted.

T2 is connected to four 16-bit Capture Registers: CT0, CT1, CT2 and CT3. A rising or falling edge on the inputs CT0I, CT1I, CT2I or CT3I (alternative function of Port 1) results in loading the contents of T2 into the respective Capture Registers and an interrupt request.

Using the Capture Register CTCON (see Table 35), these inputs may invoke capture and interrupt request on a positive edge, a negative edge or on both edges. If neither a positive nor a negative edge is selected for capture input, no capture or interrupt request can be generated by this input.

The contents of the Compare Registers CM0, CM1 and CM2 are continuously compared with the counter value of Timer T2. When a match occurs, an interrupt may be invoked. A match of CM0 sets the bits 0 to 5 of Port 4, a CM1 match resets these bits and a CM2 match toggles bits 6 and 7 of Port 4, provided these functions are enabled by the STE respectively RTE registers. A match of CM0 and CM1 at the same time results in resetting bits 0-5 of Port 4. CM0, CM1 and CM2 are reset by the RSTIN signal.

For more information concerning the TM2CON, CTCON, TM2IR and the STE/RTE registers see "Data Handbook IC20; Section 80C51 family hardware description".

Port 4 can be read and written by software without affecting the toggle, set and reset signals. At a byte overflow of the least significant byte, or at a 16-bit overflow of the timer/counter, an interrupt sharing the same interrupt vector is requested. Either one or both of these overflows can be programmed to request an interrupt.

All interrupt flags must be reset by software.

**12.2.1 T2 CONTROL REGISTER (TM2CON)****Table 31** T2 Control Register (address EAH)

7	6	5	4	3	2	1	0
T2IS1	T2IS0	T2ER	T2BO	T2P1	T2P0	T2MS1	T2MS0

**Table 32** Description of TM2CON bits

BIT	SYMBOL	DESCRIPTION
7	T2IS1	Timer T2 16-bit overflow interrupt select.
6	T2IS0	Timer T2 byte overflow interrupt select.
5	T2ER	Timer T2 external reset enable. When this bit is set, Timer T2 may be reset by a rising edge on RT2 (P1.5).
4	T2BO	Timer T2 byte overflow interrupt flag.
3	T2P1	Timer T2 prescaler select (see Table 33).
2	T2P0	
1	T2MS1	Timer T2 mode select (see Table 34).
0	T2MS0	

## 8-bit microcontroller

## P8xC557E8

**Table 33** Timer 2 prescaler select

T2P1	T2P0	TIMER T2 CLOCK
0	0	clock source
0	1	$\frac{1}{2} \times$ clock source
1	0	$\frac{1}{4} \times$ clock source
1	1	$\frac{1}{8} \times$ clock source

**Table 34** Timer 2 mode select

T2MS1	T2MS0	MODE SELECTED
0	0	Timer T2 halted (off)
0	1	$\frac{1}{12} \times f_{clk}$ T2 clock source
1	0	Test mode; do not use
1	1	T2 clock source = pin T2

## 12.2.2 CAPTURE CONTROL REGISTER (CTCON)

**Table 35** Capture Control Register (address EBH)

7	6	5	4	3	2	1	0
CTN3	CTP3	CTN2	CTP2	CTN1	CTP1	CTN0	CTP0

**Table 36** Description of CTCON bits

BIT	SYMBOL	DESCRIPTION
7	CTN3	interrupt triggered on negative edge of CT3I
6	CTP3	interrupt triggered on positive edge of CT3I
5	CTN2	interrupt triggered on negative edge of CT2I
4	CTP2	interrupt triggered on positive edge of CT2I
3	CTN1	interrupt triggered on negative edge of CT1I
2	CTP1	interrupt triggered on positive edge of CT1I
1	CTN0	interrupt triggered on negative edge of CT0I
0	CTP0	interrupt triggered on positive edge of CT0I

## 12.2.3 INTERRUPT FLAG REGISTER (TM2IR)

**Table 37** Interrupt flag register (address C8H)

7	6	5	4	3	2	1	0
T2OV	CMI2	CMI1	CMI0	CTI3	CTI2	CTI1	CTI0

**Table 38** Description of TM2IR bits

BIT	SYMBOL	DESCRIPTION
7	T2OV	T2: 16-bit overflow interrupt flag
6	CMI2	CM2: interrupt flag
5	CMI1	CM1: interrupt flag
4	CMI0	CM0: interrupt flag
3	CTI3	CT3: interrupt flag
2	CTI2	CT2: interrupt flag
1	CTI1	CT1: interrupt flag
0	CTI0	CT0: interrupt flag

## 8-bit microcontroller

## P8xC557E8

## 12.2.4 SET ENABLE REGISTER (STE)

**Table 39** Set enable register (address EEH)

7	6	5	4	3	2	1	0
TG47	TG46	SP45	SP44	SP43	SP42	SP41	SP40

**Table 40** Description of STE bits

BIT	SYMBOL	DESCRIPTION
7	TG47	If HIGH then P4.7 is reset on the next toggle, if LOW P4.7 is set on the next toggle.
6	TG46	If HIGH then P4.6 is reset on the next toggle, if LOW P4.6 is set on the next toggle.
5	SP45	If HIGH then P4.5 is set on a match between CM0 and T2.
4	SP44	If HIGH then P4.4 is set on a match between CM0 and T2.
3	SP43	If HIGH then P4.3 is set on a match between CM0 and T2.
2	SP42	If HIGH then P4.2 is set on a match between CM0 and T2.
1	SP41	If HIGH then P4.1 is set on a match between CM0 and T2.
0	SP40	If HIGH then P4.0 is set on a match between CM0 and T2.

## 12.2.5 RESET/TOGGLE ENABLE REGISTER (RTE)

**Table 41** Reset/Toggle enable register (address EFH)

7	6	5	4	3	2	1	0
TP47	TP46	RP45	RP44	RP43	RP42	RP41	RP40

**Table 42** Description of RTE bits

BIT	SYMBOL	DESCRIPTION
7	TP47	If HIGH then P4.7 toggles on a match between CM2 and T2.
6	TP46	If HIGH then P4.6 toggles on a match between CM2 and T2.
5	RP45	If HIGH then P4.5 toggles on a match between CM1 and T2.
4	RP44	If HIGH then P4.4 toggles on a match between CM1 and T2.
3	RP43	If HIGH then P4.3 toggles on a match between CM1 and T2.
2	RP42	If HIGH then P4.2 toggles on a match between CM1 and T2.
1	RP41	If HIGH then P4.1 toggles on a match between CM1 and T2.
0	RP40	If HIGH then P4.0 toggles on a match between CM1 and T2.

8-bit microcontroller

P8xC557E8

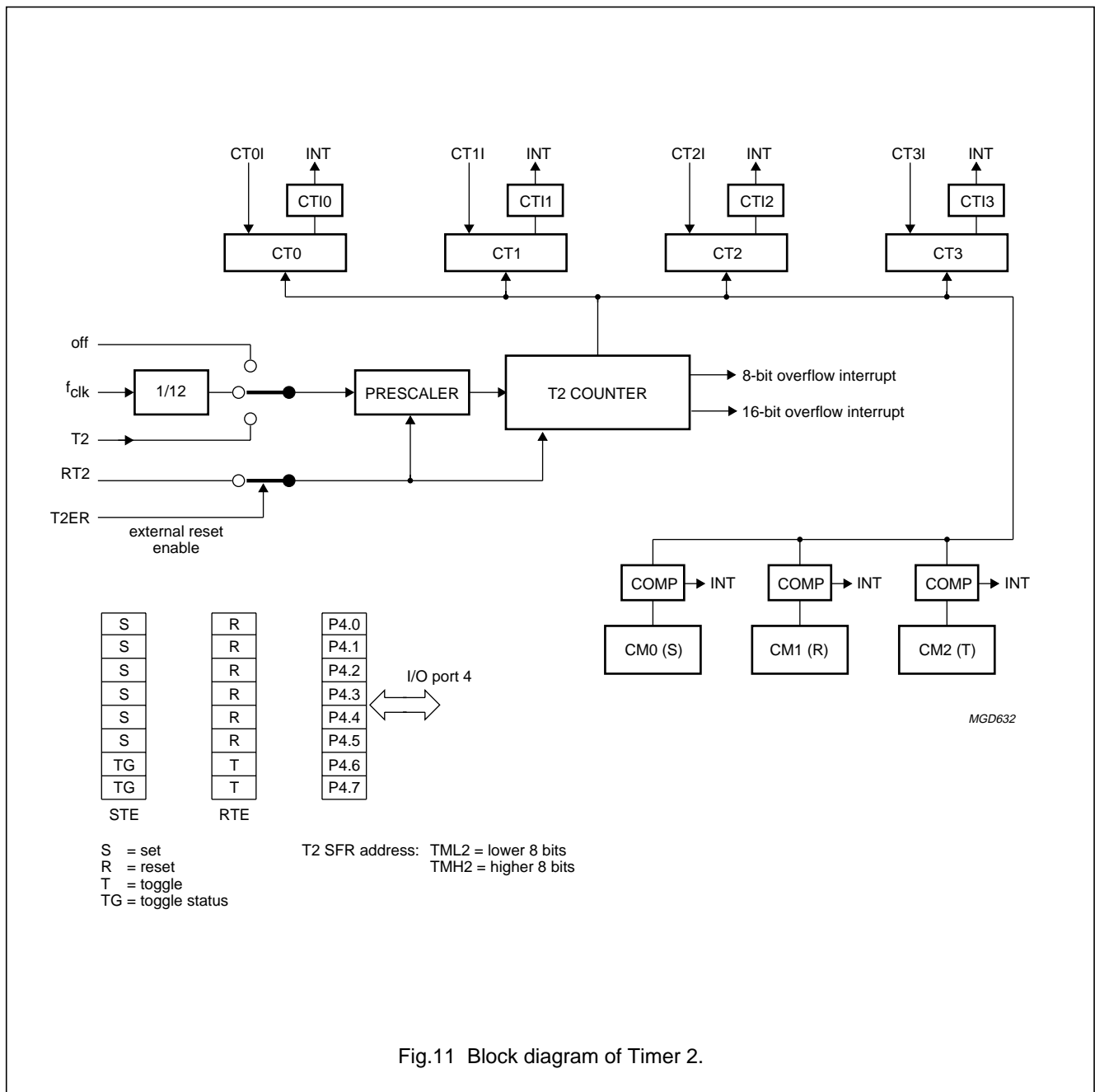

Fig.11 Block diagram of Timer 2.

8-bit microcontroller

P8xC557E8

12.3 Watchdog Timer (T3)

In addition to Timer T2 and the standard timers, a Watchdog Timer (T3) consisting of an 11-bit prescaler and an 8-bit timer is also incorporated (see Fig.12).

T3 is incremented every 1.5 ms, derived from the oscillator frequency of 16 MHz by the following formula:

$$f_{\text{timer}} = \frac{f_{\text{clk}}}{12 \times 2048}$$

When a timer overflow occurs, the microcontroller is reset and a reset output pulse is generated at pin RSTOUT. Also the PLL control register is reset.

To prevent a system reset the timer must be reloaded in time by the application software. If the processor suffers a hardware/software malfunction, the software will fail to reload the timer. This failure will produce a reset upon overflow thus preventing the processor running out of control.

The Watchdog Timer can only be reloaded if the condition flag WLE = PCON.4 has been previously set by software.

At the moment the counter is loaded the condition flag is automatically cleared.

The time interval between the timer's reloading and the occurrence of a reset depends on the reloaded value. For example, this may range from 1.5 ms to 0.375 s when using an oscillator frequency of 16 MHz.

In the Idle state the Watchdog Timer and reset circuitry remain active.

The Watchdog Timer is controlled by the watchdog enable pin ( $\overline{EW}$ ). A LOW level enables the watchdog timer and disables the Power-down mode. A HIGH level disables the watchdog timer and enables the Power-down mode.

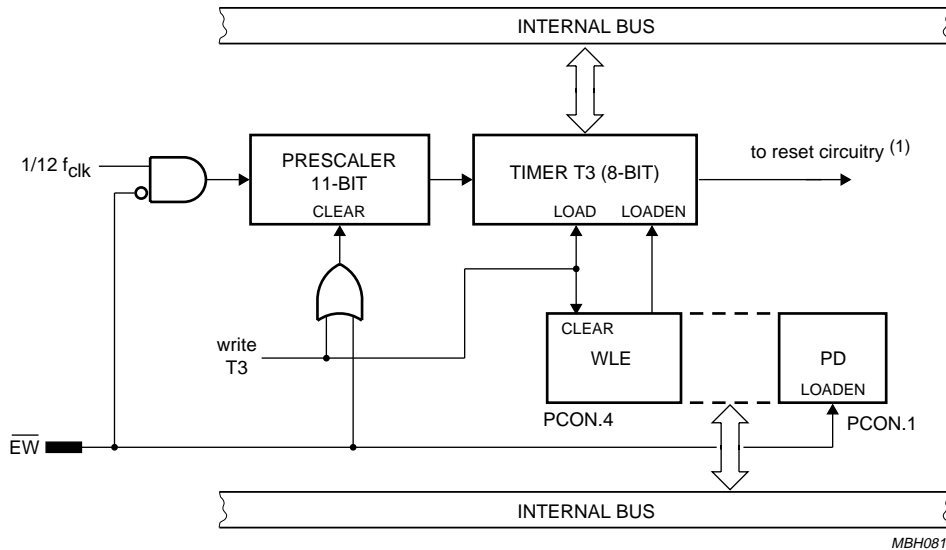

(1) See Fig.20.

Fig.12 Functional diagram of T3 Watchdog Timer.

## 8-bit microcontroller

## P8xC557E8

**13 SERIAL I/O PORTS**

The P8xC557E8 is equipped with 2 independent serial ports:

- SIO0, which is the full duplex UART port, identical to the PCB80C51 serial port
- SIO1, which is an I<sup>2</sup>C-bus serial I/O interface with byte oriented master and slave functions.

**13.1 Serial I/O Port: SIO0 (UART)**

SIO0 is a full duplex serial I/O port - it can transmit and receive simultaneously. This serial port is also receive-buffered. It can commence reception of a second byte before the previously received byte has been read from the receive register. If, however, the first byte has still not been read by the time reception of the second byte is complete, one of the bytes will be lost. The SIO0 receive and transmit registers are both accessed via the S0BUF special function register. Writing to S0BUF loads the transmit register, and reading S0BUF accesses a physically separate receive register. SIO0 can operate in four modes:

- Mode 0 Serial data is transmitted and received through RXD. TXD outputs the shift clock. 8 data bits are transmitted/received (LSB first). The baud rate is fixed at  $\frac{1}{12} \times$  the oscillator frequency. A write into S0CON should be avoided during a transmission to avoid spikes on RXD/TXD.
- Mode 1 10 bits are transmitted via TXD or received through RXD: a start bit (0), 8 data bits (LSB first), and a stop bit (1). On receive, the stop bit is put into RB8 of the S0CON SFR. The baud rate is variable.

Mode 2 11 bits are transmitted through TXD or received through RXD: a start bit (0), 8 data bits (LSB first), a programmable 9<sup>th</sup> data bit, and a stop bit (1). On transmit, the 9<sup>th</sup> data bit (TB8 in S0CON) can be assigned the value of 0 or 1. With nominal software, TB8 can be the parity bit (P in PSW). During a receive, the 9<sup>th</sup> data bit is stored in RB8 (S0CON), and the stop bit is ignored. The baud rate is programmable to either  $\frac{1}{32}$  or  $\frac{1}{64}$  of the oscillator frequency.

Mode 3 11 bits are transmitted through TXD or received through RXD: a start bit (0), 8 data bits (LSB first), a programmable 9<sup>th</sup> data bit, and a stop bit (1). Mode 3 is the same as Mode 2 except for the baud rate which is variable in Mode 3.

In all four modes, transmission is initiated by any instruction that writes to the SFR S0BUF. Reception is initiated in Mode 0 when RI = 0 and REN = 1. In the other three modes, reception is initiated by the incoming start bit provided that REN = 1.

Modes 2 and 3 are provided for multiprocessor communications. In these modes, 9 data bits are received with the 9<sup>th</sup> bit written to RB8 (S0CON). The 9<sup>th</sup> bit is followed by the stop bit. The port can be programmed so that with receiving the stop bit, the serial port interrupt will be activated if, and only if RB8 = 1.

This feature is enabled by setting bit SM2 in S0CON. It may be used in multiprocessor systems.

For more information about how to use the UART in combination with the registers S0CON, PCON, IE, SBUF and the Timer register, refer to "Data Handbook IC20".



8-bit microcontroller

P8xC557E8

13.1.1 SERIAL PORT CONTROL REGISTER (S0CON)

**Table 43** Serial Port Control Register (address 98H)

<b>7</b>	<b>6</b>	<b>5</b>	<b>4</b>	<b>3</b>	<b>2</b>	<b>1</b>	<b>0</b>
SM0	SM1	SM2	REN	TB8	RB8	TI	RI

**Table 44** Description of S0CON bits

BIT	SYMBOL	DESCRIPTION
7	SM0	These bits are used to select the serial port mode; see Table 45.
6	SM1	
5	SM2	Enables the multiprocessor communication feature in Modes 2 and 3. In these modes, if SM2 = 1, then RI will not be activated if the received 9 <sup>th</sup> data bit (RB8) is a logic 0. In Mode 1, if SM2 = 1, then RI will not be activated if a valid stop bit was not received. In Mode 0, SM2 should be a logic 0.
4	REN	Enables serial reception. Set by software to enable reception. Clear by software to disable reception.
3	TB8	The 9 <sup>th</sup> data bit that will be transmitted in modes 2 and 3. Set or clear by software as desired.
2	RB8	In modes 2 and 3, RB8 is the 9 <sup>th</sup> data bit that was received. In Mode 1, if SM2 = 0, RB8 is the stop bit that was received. In Mode 0, RB8 is not used.
1	TI	<b>Transmit Interrupt flag.</b> Set by hardware at the end of the 8 <sup>th</sup> bit time in Mode 0, or at the beginning of the stop bit in the other modes, in any serial transmission. Must be cleared by software.
0	RI	<b>Receive Interrupt flag.</b> Set by hardware at the end of the 8 <sup>th</sup> bit time in Mode 0, or halfway through the stop bit time in the other modes, in any serial reception (except see SM2). Must be cleared by software.

**Table 45** Serial port mode select

SM0	SM1	MODE	DESCRIPTION	BAUD RATE
0	0	Mode 0	Shift register	$\frac{1}{12} \times f_{clk}$
0	1	Mode 1	8-bit UART	variable
1	0	Mode 2	9-bit UART	$\frac{1}{64}$ or $\frac{1}{32} \times f_{clk}$
1	1	Mode 3	9-bit UART	variable

## 8-bit microcontroller

## P8xC557E8

**13.2 Serial I/O Port: SIO1 (I<sup>2</sup>C-bus interface)**

The SIO1 of the P8xC557E8 provides the fast mode, which allows a fourth-fold increase of the bit rate up to 400 kHz. Nevertheless it is downward compatible, i.e. it can be used in a 0 to 100 kbit/s I<sup>2</sup>C-bus system.

Except from the bit rate selection (see Table 48) and the timing of the SCL and SDA signals (see Chapter 11) the SIO circuit is the same as described in detail in the 80C51-based *"Data Handbook IC20"* for the 8xC552 microcontroller.

The I<sup>2</sup>C-bus is a simple bidirectional 2-wire bus for efficient inter-IC data exchange. Features of the I<sup>2</sup>C-bus are:

- Only two bus lines are required: a serial clock line (SCL) and a serial data line (SDA)
- Each device connected to the bus is software addressable by a unique address
- Masters can operate as master transmitter or as master receiver
- It is a true multi-master bus including collision detection and arbitration to prevent data corruption if two or more masters simultaneously initiate data transfer
- Serial clock synchronization allows devices with different bit rates to communicate via the same serial bus
- ICs can be added to or removed from an I<sup>2</sup>C-bus system without affecting any other circuit on the bus
- Fault diagnostics and debugging are simple; malfunctions can be immediately traced.

For more information on the I<sup>2</sup>C-bus specification (including fast-mode) please refer to the Philips publication *"The I<sup>2</sup>C-bus and how to use it"* ordering number 9398 393 40011 and/or the 80C51-based *"Data Handbook IC20"*.

The on-chip I<sup>2</sup>C logic provides a serial interface that meets the I<sup>2</sup>C-bus specification, supporting 4 modes of operation:

- Master transmitter
- Master receiver
- Slave transmitter
- Slave receiver.

The SIO1 logic performs a byte oriented data transport; clock generation, address recognition and bus control arbitration are all controlled by hardware. Via two pins the external I<sup>2</sup>C-bus is interfaced to the SIO1 logic: SCL serial clock I/O and SDA serial data I/O (SFR S1CON bit ENS1 for enabling the SIO1 logic).

The SIO1 logic handles byte transfer autonomously. It keeps track of the serial transfers, and a status register (S1STA) reflects the status of SIO1 and the I<sup>2</sup>C-bus.

Via 4 SFRs the CPU interfaces to the I<sup>2</sup>C-bus logic:

- S1CON; Serial Control Register. Bit-addressable by the CPU
- S1STA; Status Register whose contents may be used as a vector to service routines
- S1DAT; Data Shift Register. The data byte is stable as long as SI = 1 (SFR S1CON)
- S1ADR; Slave Address Register. Its LSB enables/disables general call address recognition.

**13.2.1 SERIAL CONTROL REGISTER (S1CON)**

The CPU can read from and write to this 8-bit, directly addressable SFR. Two bits are affected by the SIO1 hardware:

- the SI bit is set when a serial interrupt is requested, and
- the STO bit is cleared when a STOP condition is present on the I<sup>2</sup>C-bus. The STO bit is also cleared when ENS1 = 0.

When SIO1 is in a master mode, serial clock frequency is determined by the clock rate bits CR2, CR1 and CR0. The various bit rates are shown in Table 48.

The data shown in Table 48 do not apply to SIO1 in a slave mode. In the slave modes, SIO1 will automatically synchronize with any clock frequency up to 400 kHz. However, serial clock frequencies above 100 kHz require an oscillator frequency  $f_{clk}$  of at least 12 MHz.

## 8-bit microcontroller

## P8xC557E8

**Table 46** Serial Control Register (address D8H)

7	6	5	4	3	2	1	0
CR2	ENS1	STA	STO	SI	AA	CR1	CR0

**Table 47** Description of S1CON bits

BIT	SYMBOL	DESCRIPTION
7	CR2	Clock rate bit 2, see Table 48.
6	ENS1	<b>Enable serial I/O.</b> ENS1 = 0: serial I/O disabled and reset. SDA and SCL outputs are high-Z. ENS1 = 1: serial I/O enabled.
5	STA	<b>START flag.</b> When this bit is set in slave mode, the hardware checks the I <sup>2</sup> C-bus and generates a START condition if the bus is free or after the bus becomes free. If the device operates in master mode it will generate a repeated START condition.
4	STO	<b>STOP flag.</b> If this bit is set in a master mode a STOP condition is generated. A STOP condition detected on the I <sup>2</sup> C-bus clears this bit. This bit may also be set in slave mode in order to recover from an error condition. In this case no STOP condition is generated to the I <sup>2</sup> C-bus, but the hardware releases the SDA and SCL lines and switches to the not selected receiver mode. The STOP flag is cleared by the hardware.
3	SI	<b>Serial Interrupt flag.</b> This flag is set and an interrupt request is generated, after any of the following events occur: <ul style="list-style-type: none"> <li>• A START condition is generated in master mode.</li> <li>• The own slave address has been received during AA = 1.</li> <li>• The general call address has been received while GC (bit S1ADR.0) and AA = 1.</li> <li>• A data byte has been received or transmitted in master mode (even if arbitration is lost).</li> <li>• A data byte has been received or transmitted as selected slave.</li> <li>• A STOP or START condition is received as selected slave receiver or transmitter.</li> </ul> While the SI flag is set, SCL remains LOW and the serial transfer is suspended. SI must be reset by software.
2	AA	<b>Assert Acknowledge flag.</b> When this bit is set, an acknowledge is returned after any one of the following conditions: <ul style="list-style-type: none"> <li>• Own slave address is received.</li> <li>• General call address is received; GC (bit S1ADR.0) = 1.</li> <li>• A data byte is received, while the device is programmed to be a master receiver.</li> <li>• A data byte is received. while the device is a selected slave receiver.</li> </ul> When the bit is reset, no acknowledge is returned. Consequently, no interrupt is requested when the own address or general call address is received.
1	CR1	Clock rate bits 1 and 0; see Table 48.
0	CR0	

8-bit microcontroller

P8xC557E8

**Table 48** Selection of I<sup>2</sup>C-bus bit rate

CR2	CR1	CR0	BIT RATE (kbits/s) at f <sub>clk</sub>	
			12 MHz	16 MHz
1	0	0	50	66.7
1	0	1	3.75	5
1	1	0	75	100
1	1	1	100	–
0	0	0	200 <sup>(1)</sup>	266.7 <sup>(1)</sup>
0	0	1	7.5	10
0	1	0	300 <sup>(1)</sup>	400 <sup>(1)</sup>
0	1	1	400 <sup>(1)</sup>	–

**Note**

1. These bit rates are for 'fast-mode' I<sup>2</sup>C-bus applications and cannot be used for standard I<sup>2</sup>C bit rates up to 100 kbits/s.

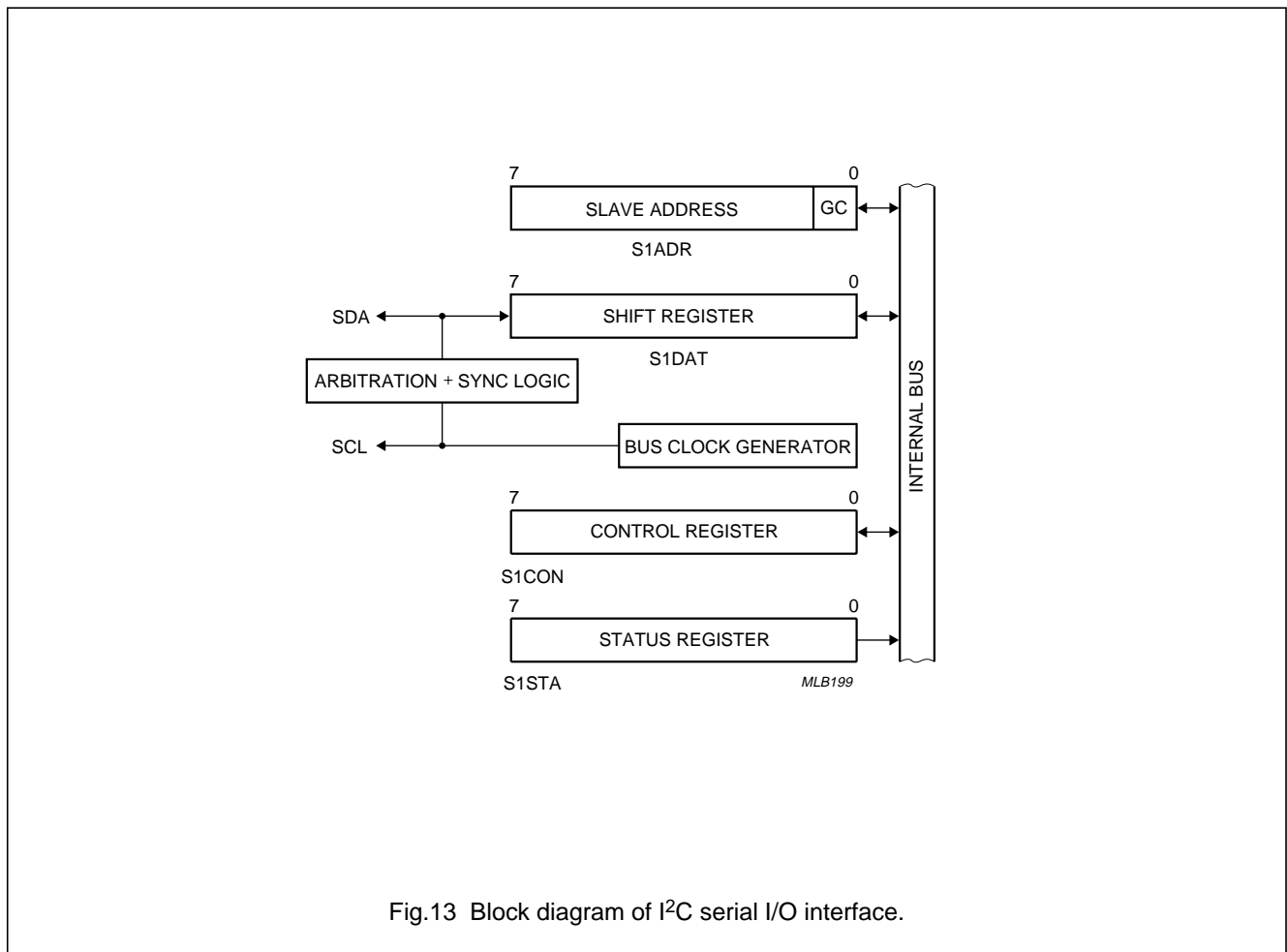

Fig.13 Block diagram of I<sup>2</sup>C serial I/O interface.

## 8-bit microcontroller

## P8xC557E8

## 13.2.2 SERIAL STATUS REGISTER (S1STA)

The contents of this register may be used as a vector to a service routine. This optimizes the response time of the software and consequently that of the I<sup>2</sup>C-bus. S1STA is a read-only register. The status codes for all possible modes of the I<sup>2</sup>C-bus interface are given in Tables 51 to 55.

**Table 49** Serial status register (address D9H)

<b>7</b>	<b>6</b>	<b>5</b>	<b>4</b>	<b>3</b>	<b>2</b>	<b>1</b>	<b>0</b>
SC4	SC3	SC2	SC1	SC0	0	0	0

**Table 50** Description of S1STA bits

BIT	SYMBOL	DESCRIPTION
7 to 3	SC4 to SC0	5-bit status code.
2 to 0	–	These 3 bits are held LOW (for service routine vector increment 8).

**Table 51** MST/TRX mode

S1STA VALUE	DESCRIPTION
08H	A START condition has been transmitted.
10H	A repeated START condition has been transmitted.
18H	SLA and W have been transmitted, ACK has been received.
20H	SLA and W have been transmitted, $\overline{\text{ACK}}$ received.
28H	DATA and S1DAT has been transmitted, ACK received.
30H	DATA and S1DAT has been transmitted, $\overline{\text{ACK}}$ received.
38H	Arbitration lost in SLA, R/W or DATA.

**Table 52** MST/REC mode

S1STA VALUE	DESCRIPTION
38H	Arbitration lost while returning $\overline{\text{ACK}}$ .
40H	SLA and R have been transmitted, ACK received.
48H	SLA and R have been transmitted, $\overline{\text{ACK}}$ received.
50H	DATA has been received, ACK returned.
58H	DATA has been received, $\overline{\text{ACK}}$ returned.

## 8-bit microcontroller

## P8xC557E8

**Table 53** SLV/REC mode

S1STA VALUE	DESCRIPTION
60H	Own SLA and W have been received, ACK returned.
68H	Arbitration lost in SLA, R/W as MST. Own SLA and W have been received, $\overline{\text{ACK}}$ returned.
70H	General CALL has been received, ACK returned.
78H	Arbitration lost in SLA, R/W as MST. General call has been received.
80H	Previously addressed with own SLA. DATA byte received, ACK returned.
88H	Previously addressed with own SLA. DATA byte received, $\overline{\text{ACK}}$ returned.
90H	Previously addressed with general call. DATA byte has been received, ACK has been returned.
98H	Previously addressed with general call. DATA byte has been received, $\overline{\text{ACK}}$ has been returned.
A0H	A STOP condition or repeated START condition has been received while still addressed as SLV/REC or SLV/TRX.

**Table 54** SLV/TRX mode

S1STA VALUE	DESCRIPTION
A8H	Own SLA and R have been received, ACK returned.
B0H	Arbitration lost in SLA, R/W as MST. Own SLA and R have been received, ACK returned.
B8H	DATA byte has been transmitted, ACK returned.
C0H	DATA byte has been transmitted, $\overline{\text{ACK}}$ returned.
C8H	Last DATA byte has been transmitted (AA = logic 0), ACK received.

**Table 55** Miscellaneous

S1STA VALUE	DESCRIPTION
00H	Bus error during MST mode or selected SLV mode, due to an erroneous START or STOP condition.
F8H	No relevant information available, SI not set.

**Table 56** Symbols used in Tables 51 to 55

SYMBOL	DESCRIPTION
SLA	7-bit slave address
R	read bit
W	write bit
ACK	acknowledgement (acknowledge bit = logic 0)
$\overline{\text{ACK}}$	no acknowledgement (acknowledge bit = logic 1)
DATA	8-bit data byte to or from I <sup>2</sup> C-bus
MST	master
SLV	slave
TRX	transmitter
REC	receiver

## 8-bit microcontroller

## P8xC557E8

## 13.2.3 DATA SHIFT REGISTER (S1DAT)

This register contains the serial data to be transmitted or data which has been received. Bit 7 is transmitted or received first; i.e. data is shifted from right to left.

**Table 57** Data Shift Register (address DAH)

<b>7</b>	<b>6</b>	<b>5</b>	<b>4</b>	<b>3</b>	<b>2</b>	<b>1</b>	<b>0</b>
S1DAT.7	S1DAT.6	S1DAT.5	S1DAT.4	S1DAT.3	S1DAT.2	S1DAT.1	S1DAT.0

## 13.2.4 ADDRESS REGISTER (S1ADR)

This 8-bit register may be loaded with the 7-bit slave address to which the controller will respond when programmed as a slave receiver/transmitter.

**Table 58** Address Register (address DBH)

<b>7</b>	<b>6</b>	<b>5</b>	<b>4</b>	<b>3</b>	<b>2</b>	<b>1</b>	<b>0</b>
SLA6	SLA5	SLA4	SLA3	SLA2	SLA1	SLA0	GC

**Table 59** Description of S1ADR bits

<b>BIT</b>	<b>SYMBOL</b>	<b>DESCRIPTION</b>
7 to 1	SLA6 to SLA0	Own slave address.
0	GC	This bit is used to determine whether the general call address is recognized. When GC = 0, the general call address is not recognized; when GC = 1, the general call address is recognized.

## 8-bit microcontroller

## P8xC557E8

**14 INTERRUPT SYSTEM**

External events and the real-time-driven on-chip peripherals require service by the CPU asynchronously to the execution of any particular section of code. To tie the asynchronous activities of these functions to normal program execution a multiple-source, two-priority-level, nested interrupt system is provided. Interrupt response time in a single-interrupt system is in the range 2.25  $\mu$ s to 6.75  $\mu$ s when using a 16 MHz crystal. The latency time depends on the sequence of instructions executed directly after an interrupt request.

The P8xC557E8 acknowledges interrupt requests from 15 sources as follows (see Fig.14):

- $\overline{\text{INT0}}$  and  $\overline{\text{INT1}}$  external interrupts
- Timer 0 and Timer 1 internal timer/counter interrupts
- Timer 2 internal timer/counter byte and/or 16-bit overflow, 3 compare and 4 capture interrupts (or 4 additional external interrupts).

Note that if a capture register is unused and its contents are of no interest, then the corresponding input pin CTn/P1.n (n = 0 to 3) may be used as a (configurable) positive and/or negative edge triggered additional external interrupt input ( $\overline{\text{INT2}}$ ,  $\overline{\text{INT3}}$ ,  $\overline{\text{INT4}}$  and  $\overline{\text{INT5}}$ ).

- UART serial I/O port receive/transmit interrupt
- I<sup>2</sup>C-bus interface serial I/O interrupt
- ADC autoscan completion interrupt
- 'Seconds' timer interrupt SEC (ORed with  $\overline{\text{INT1}}$ ); for details please refer to Chapter 16.2.4.

The External Interrupts  $\overline{\text{INT0}}$  and  $\overline{\text{INT1}}$  can each be either level-activated or transition-activated, depending on bits IT0 and IT1 in register TCON. The flags that actually generate these interrupts are bits IE0 and IE1 in TCON. When an external interrupt is generated, the corresponding request flag is cleared by the hardware when the service routine is vectored to, only if the interrupt was transition-activated. If the interrupt was level-activated then the interrupt request flag remains set until the external interrupt pin  $\overline{\text{INTn}}$  goes HIGH. Consequently, the external source has to hold the request active until the requested interrupt is actually generated. Then it has to deactivate the request before the interrupt service routine is completed, or else another interrupt will be generated. As these external interrupts are active LOW a 'wire-ORing' of several interrupt sources to one input pin allows expansion.

The Timer 0 and Timer 1 interrupts are generated by TF0 and TF1, which are set by a roll-over in their respective timer/counter register (except for Timer 0 in Mode 3 of the serial interface). When a Timer interrupt is generated, the flag that generated it is cleared by the on-chip hardware when the service routine is vectored to.

The eight Timer/Counter T2 Interrupt sources are: 4 capture Interrupts (1), 3 compare interrupts and an overflow interrupt. The appropriate interrupt request flags must be cleared by software.

The UART Serial Port Interrupt is generated by the logical OR of RI and TI (register S0CON). Neither of these flags is cleared by hardware. The service routine will normally have to determine whether it was RI or TI that generated the interrupt, and the bit will have to be cleared by software.

The I<sup>2</sup>C Interrupt is generated by bit SI in register S1CON. This flag has to be cleared by software.

The ADC Interrupt is generated by bit ADINT, which is set when the conversion of all selected analog inputs to be scanned is finished. ADINT must be cleared by software. It cannot be set by software.

The 'seconds' timer Interrupt is generated by bit SECINT in register PLLCON. This flag has to be cleared by software. Note that the 'seconds' timer can only be used with the 32 kHz PLL oscillator.

All of the bits that generate interrupts can be set or cleared by software, with the same result as though they had been set or cleared by hardware (except the ADC interrupt request flag ADINT, which cannot be set by software). That is, interrupts can be generated or pending interrupts can be cancelled in software.

The Interrupts X0, T0, X1, T1, SEC, S0 and S1 are able to terminate the Idle mode.

**14.1 Interrupt Enable Registers**

Each interrupt source can be individually enabled or disabled by setting or clearing a bit in the interrupt enable Special Function Registers IEN0 and IEN1. All interrupt sources can also be globally disabled by clearing bit EA in IEN0. The interrupt enable registers are described in Tables 62 and 64.



## 8-bit microcontroller

## P8xC557E8

**14.2 Interrupt Handling**

The interrupt sources are sampled at S5P2 of every machine cycle. The samples are polled during the following machine cycle. If one of the flags was in a set condition at S5P2 of the previous machine cycle, the polling cycle will detect it and the interrupt system will generate an LCALL to the appropriate service routine, provided this hardware generated LCALL is not blocked by any of the following conditions:

1. An interrupt of higher or equal priority level is already in progress.
2. The current machine cycle is not the final cycle in the execution of the instruction in progress. (No interrupt request will be serviced until the instruction in progress is completed.).
3. The instruction in progress is RETI or any access to the interrupt priority or interrupt enable registers. (No interrupt will be serviced after RETI or after a read or write to IP0, IP1, IE0, or IE1 until at least one other instruction has been subsequently executed.).

The polling cycle is repeated every machine cycle, and the values polled are the values present at S5P2 of the previous machine cycle. Note that if an interrupt flag is active but is not being responded to because of one of the above conditions, and if the flag is inactive when the blocking condition is removed, then the blocked interrupt will not be serviced. Thus, the fact that the interrupt flag was once active but not serviced is not remembered. Every polling cycle is new.

The processor acknowledges an interrupt request by executing a hardware-generated LCALL to the appropriate service routine. In some cases it also clears the flag which generated the interrupt, and in others it does not. It clears the Timer 0, Timer 1, and external interrupt flags. An external interrupt flag (IE0 or IE1) is cleared only if it was transition-activated. All other interrupt flags are not cleared by hardware and must be cleared by the software.

The LCALL pushes the contents of the program counter on to the stack (but it does not save the PSW) and reloads the PC with an address that depends on the source of the interrupt being vectored to as shown in Table 60.

Execution proceeds from the vector address until the RETI instruction is encountered. The RETI instruction clears the 'priority level active' flip-flop that was set when this interrupt was acknowledged. It then pops the top two bytes from the stack and reloads the program counter. Execution of the interrupted program continues from where it was interrupted.

**14.3 Interrupt Priority Structure**

Each interrupt source can be assigned one of two priority levels: high and low. Interrupt priority levels are defined by the interrupt priority SFRs IP0 and IP1, which are described in Tables 66 and 68.

Interrupt priority levels are as follows:

- logic 0 = low priority
- logic 1 = high priority.

A low priority interrupt may be interrupted by a high priority interrupt. A high priority interrupt cannot be interrupted by any other interrupt source. If two requests of different priority occur simultaneously, the high priority level request is serviced. If requests of the same priority are received simultaneously, an internal polling sequence determines which request is serviced. Thus, within each priority level, there is a second priority structure determined by the polling sequence. This second priority structure is shown in Table 60.

**14.4 Interrupt vectors**

The vector indicates the Program Memory location where the appropriate interrupt service routine starts; Table 60.

**Table 60** Interrupt vectors and priority structure

SOURCE	SYMBOL <sup>(1)</sup>	VECTOR ADDRESS (HEX)
External 0	X0 (highest)	0003
Serial I/O: SIO1 (I <sup>2</sup> C-bus)	S1	002B
ADC completion	ADC	0053
Timer 0 overflow	T0	000B
T2 capture 0	CT0	0033
T2 compare 0	CM0	005B
External 1/ seconds interrupt	X1/SEC	0013
T2 capture 1	CT1	0033
T2 compare 1	CM1	0063
Timer 1 overflow	T1	001B
T2 capture 2	CT2	0043
T2 compare 2	CM2	006B
Serial I/O SIO0 (UART)	S0	0023
T2 capture 3	CT3	004B
T2 overflow	T2 (lowest)	0073

**Note**

1. X0 has the highest priority; T2 the lowest.

8-bit microcontroller

P8xC557E8

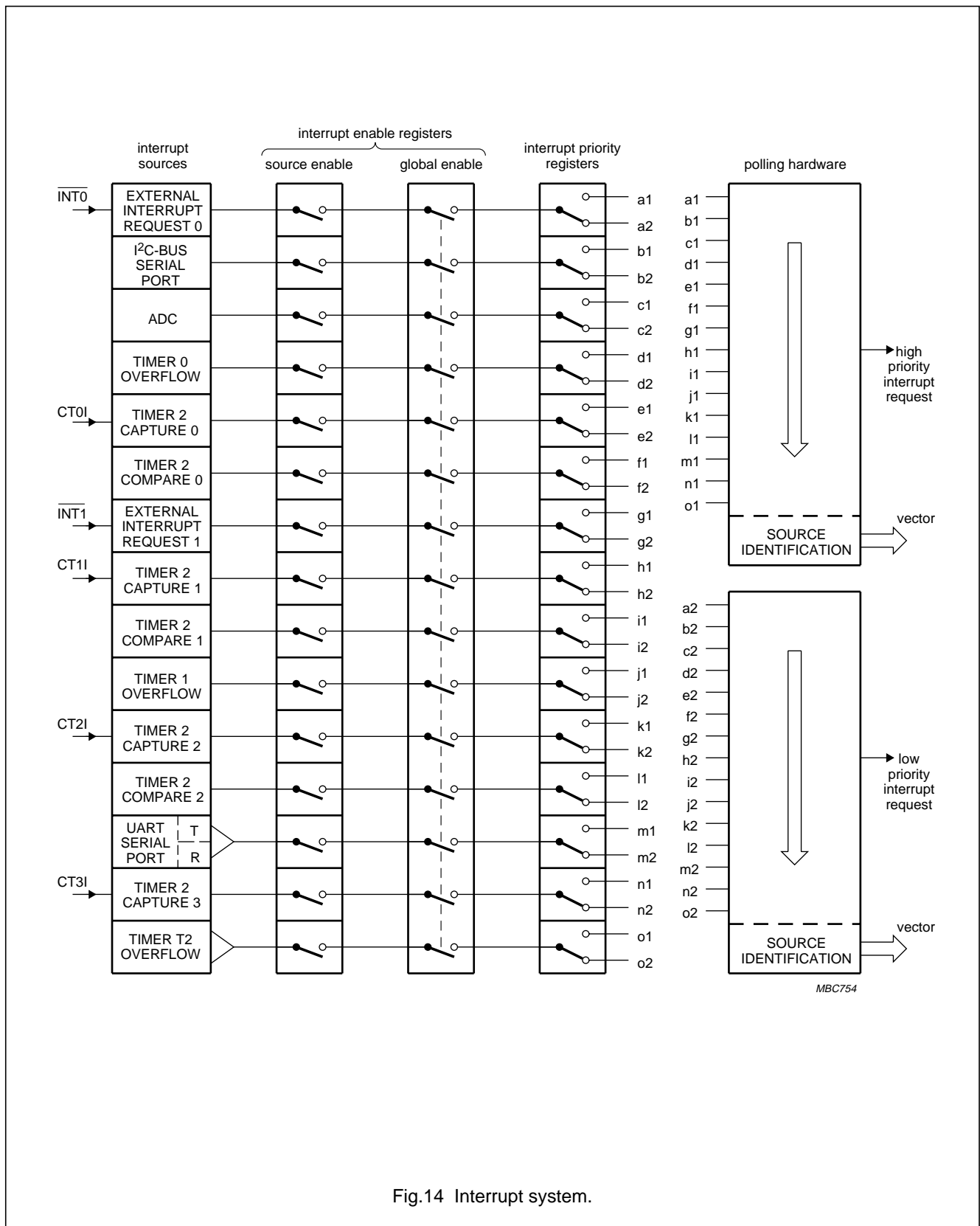

Fig.14 Interrupt system.

## 8-bit microcontroller

## P8xC557E8

**14.5 Interrupt Enable and Priority Registers**

## 14.5.1 INTERRUPT ENABLE REGISTER 0 (IEN0)

Logic 0 = interrupt disabled; logic 1 = interrupt enabled.

**Table 61** Interrupt Enable Register 0 (address A8H)

7	6	5	4	3	2	1	0
EA	EAD	ES1	ES0	ET1	EX1	ET0	EX0

**Table 62** Description of IEN0 bits

BIT	SYMBOL	DESCRIPTION
7	EA	<b>General enable/disable control.</b> If bit $\overline{EA}$ is: LOW, then no interrupt is enabled. HIGH, then any individually enabled interrupt will be accepted.
6	EAD	Enable ADC interrupt.
5	ES1	Enable SIO1 (I <sup>2</sup> C-bus) interrupt.
4	ES0	Enable SIO0 (UART) interrupt.
3	ET1	Enable Timer 1 interrupt.
2	EX1	Enable External 1 interrupt / Seconds interrupt.
1	ET0	Enable Timer 0 interrupt.
0	EX0	Enable External 0 interrupt.

## 14.5.2 INTERRUPT ENABLE REGISTER 1 (IEN1)

Logic 0 = interrupt disabled; logic 1 = interrupt enabled.

**Table 63** Interrupt Enable Register 1 (address E8H)

7	6	5	4	3	2	1	0
ET2	ECM2	ECM1	ECM0	ECT3	ECT2	ECT1	ECT0

**Table 64** Description of IEN1 bits

BIT	SYMBOL	DESCRIPTION
7	ET2	Enable T2 overflow interrupt(s).
6	ECM2	Enable T2 comparator 2 interrupt.
5	ECM1	Enable T2 comparator 1 interrupt.
4	ECM0	Enable T2 comparator 0 interrupt.
3	ECT3	Enable T2 capture register 3 interrupt.
2	ECT1	Enable T2 capture register 2 interrupt.
1	ECT1	Enable T2 capture register 1 interrupt.
0	ECT0	Enable T2 capture register 0 interrupt.

## 8-bit microcontroller

## P8xC557E8

## 14.5.3 INTERRUPT PRIORITY REGISTER 0 (IP0)

Logic 0 = low priority; logic 1 = high priority.

**Table 65** Interrupt Priority Register 0 (address B8H)

<b>7</b>	<b>6</b>	<b>5</b>	<b>4</b>	<b>3</b>	<b>2</b>	<b>1</b>	<b>0</b>
–	PAD	PS1	PS0	PT1	PX1	PT0	PX0

**Table 66** Description of IP0 bits

<b>BIT</b>	<b>SYMBOL</b>	<b>DESCRIPTION</b>
7	–	Reserved for future use.
6	PAD	ADC interrupt priority level.
5	PS1	SIO1 (I <sup>2</sup> C-bus) interrupt priority level.
4	PS0	SIO0 (UART) interrupt priority level.
3	PT1	Timer 1 interrupt priority level.
2	PX1	External interrupt 1/Seconds priority level.
1	PT0	Timer 0 interrupt priority level.
0	PX0	External interrupt 0 priority level.

## 14.5.4 INTERRUPT PRIORITY REGISTER 1 (IP1)

Logic 0 = low priority; logic 1 = high priority.

**Table 67** Interrupt Priority Register 1 (address F8H)

<b>7</b>	<b>6</b>	<b>5</b>	<b>4</b>	<b>3</b>	<b>2</b>	<b>1</b>	<b>0</b>
PT2	PCM2	PCM1	PCM0	PCT3	PCT2	PCT1	PCT0

**Table 68** Description of IP1 bits

<b>BIT</b>	<b>SYMBOL</b>	<b>DESCRIPTION</b>
7	PT2	T2 overflow interrupt(s) priority level.
6	PCM2	T2 comparator 2 priority interrupt level.
5	PCM1	T2 comparator 1 priority interrupt level.
4	PCM0	T2 comparator 0 priority interrupt level.
3	PCT3	T2 capture register 3 priority interrupt level.
2	PCT2	T2 capture register 2 priority interrupt level.
1	PCT1	T2 capture register 1 priority interrupt level.
0	PCT0	T2 capture register 0 priority interrupt level.

## 8-bit microcontroller

## P8xC557E8

### 15 REDUCED POWER MODES

Two software-selectable modes of reduced power consumption are implemented: Idle and Power-down mode. These modes are activated by software via SFR PCON.

#### 15.1 Idle mode

Idle mode operation permits the interrupt, serial ports and timer blocks T0, T1 and T3 to function while the CPU is halted. The functions that are switched off when the microcontroller enters the Idle mode are:

- CPU (halted)
- Timer 2 (stopped and reset)
- $\overline{\text{PWM0}}$ ,  $\overline{\text{PWM1}}$  (reset, output = HIGH)
- ADC (aborted if conversion in progress).

The functions that remain active during Idle mode may generate an interrupt or reset and thus terminate the Idle mode. These functions are:

- Timer 0, Timer 1, Timer 3 (Watchdog Timer)
- UART
- I<sup>2</sup>C
- External interrupt
- Seconds timer.

The instruction that sets PCON.0 is the last instruction executed in the normal operating mode before Idle mode is activated.

Once in the Idle mode, the CPU status is preserved in its entirety: the Stack Pointer, Program Counter, Program Status Word, Accumulator, RAM and all other registers maintain their data during Idle mode. The status of external pins during Idle mode is shown in Table 69.

There are three ways to terminate the Idle mode:

- Activation of any enabled interrupt X0, T0, X1, SEC, T1, S0 or S1 will cause PCON.0 to be cleared by hardware terminating Idle mode but only, if there is no interrupt in service with the same or higher priority. The interrupt is serviced, and following return from interrupt instruction RETI, the next instruction to be executed will be the one which follows the instruction that wrote a logic 1 to PCON.0.

The flag bits GF0 and GF1 may be used to determine whether the interrupt was received during normal execution or during Idle mode.

For example, the instruction that writes to PCON.0 can also set or clear one or both flag bits.

When Idle mode is terminated by an interrupt, the service routine can examine the status of the flag bits.

- The second way of terminating the Idle mode is with an external hardware reset. Since the oscillator is still running, the hardware reset is required to be active for two machine cycles (24 HF oscillator periods) to complete the reset operation if the HF oscillator is selected.

When the PLL oscillator is selected a hardware reset of  $\geq 1 \mu\text{s}$  (but no longer than 10 ms) is required and the microcontroller will typically restart within 63 ms after the reset has finished.

- The third way of terminating the Idle mode is by internal watchdog reset. The microcontroller restarts after three machine cycles in all cases.

#### 15.2 Power-down mode

In Power-down mode the system clock is halted. If the PLL oscillator is selected (SELXTAL1 = 0) and the RUN32 bit is set, the 32 kHz oscillator keeps running, otherwise it is stopped. If the HF oscillator (SELXTAL1 = 1) is selected, it is stopped after setting the bit PD in the PCON register.

The instruction that sets PCON.1 is the last executed prior to going into the Power-down mode. Once in Power-down mode, the HF oscillator is stopped.

The 32 kHz oscillator may remain active. The contents of the on-chip RAM and the Special Function Registers are preserved.

Note that the Power-down mode can not be entered when the Watchdog Timer has been enabled.

The Power-down mode can be terminated by an external reset in the same way as in the 80C51 (RAM is saved, but SFRs are cleared due to reset) or in addition by any one of the external interrupts ( $\overline{\text{INT0}}$ ,  $\overline{\text{INT1}}$ ) or Seconds interrupt.

The status of the external pins during Power-down mode is shown in Table 69. If the Power-down mode is activated while in external Program Memory, the port data that is held in the Special Function Register P2 is restored to Port 2. If the data is a logic 1, the port pin is held HIGH during the Power-down mode by the strong pull-up transistor P1 (see Fig.8).

The Power-down mode should not be entered within an interrupt routine because Wake-up with an external or 'Seconds' interrupt is not possible in that case.

8-bit microcontroller

P8xC557E8

15.3 Wake-up from Power-down mode

The Power-down mode of the P8xC557E8 can also be terminated by any one of the three enabled interrupts,  $\overline{\text{INT0}}$ ,  $\overline{\text{INT1}}$  or Seconds interrupt.

If there is an interrupt already in service, which has same or higher priority than the Wake-up interrupt, Power-down mode will switch over to Idle mode and stay there until an interrupt of higher priority terminates Idle mode.

A termination with these interrupts does not affect the internal Data Memory and does not affect the Special Function Registers. This gives the possibility to exit Power-down without changing the port output levels.

To terminate the Power-down mode with an external interrupt,  $\overline{\text{INT0}}$  or  $\overline{\text{INT1}}$  must be switched to be level-sensitive and must be enabled. The external interrupt input signal  $\overline{\text{INT0}}$  or  $\overline{\text{INT1}}$  must be kept LOW till the oscillator has restarted and stabilized (see Fig.15).

A Seconds interrupt will terminate the Power-down mode if it is enabled and  $\overline{\text{INT1}}$  is level sensitive. In order to prevent any interrupt priority problems during Wake-up, the priority of the desired Wake-up interrupt should be higher than the priorities of all other enabled interrupt sources.

The instruction following the one that put the device into the Power-down mode will be the first one which will be executed after the interrupt routine has been serviced.

15.4 Status of external pins

Table 69 Status of external pins during Idle and Power-down modes

MODE	MEMORY	ALE	$\overline{\text{PSEN}}$	PWM0/ PWM1	PORT0	PORT1	PORT2	PORT3	PORT4	SCL/ SDA
Idle	internal	1	1	1	port data	port data	port data	port data	port data	operative <sup>(1)</sup>
	external	1	1	1	high-Z	port data	address	port data	port data	operative <sup>(1)</sup>
Power-down	internal	0	0	1	port data	port data	port data	port data	port data	high-Z
	external	0	0	1	high-Z	port data	port data	port data	port data	high-Z

Note

- In Idle mode SCL and SDA can be active as outputs only if SIO1 is enabled; if SIO1 is disabled (S1CON.6/ENS1 = 0) these pins are in a high-impedance state.

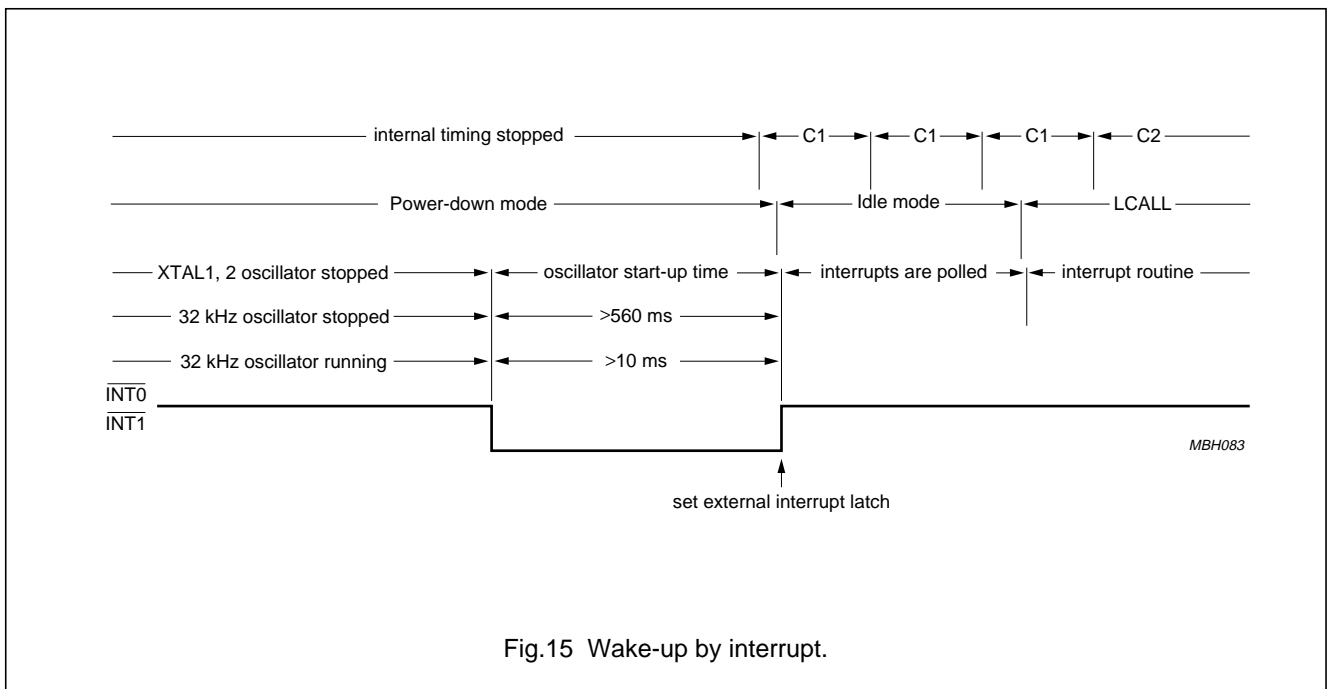
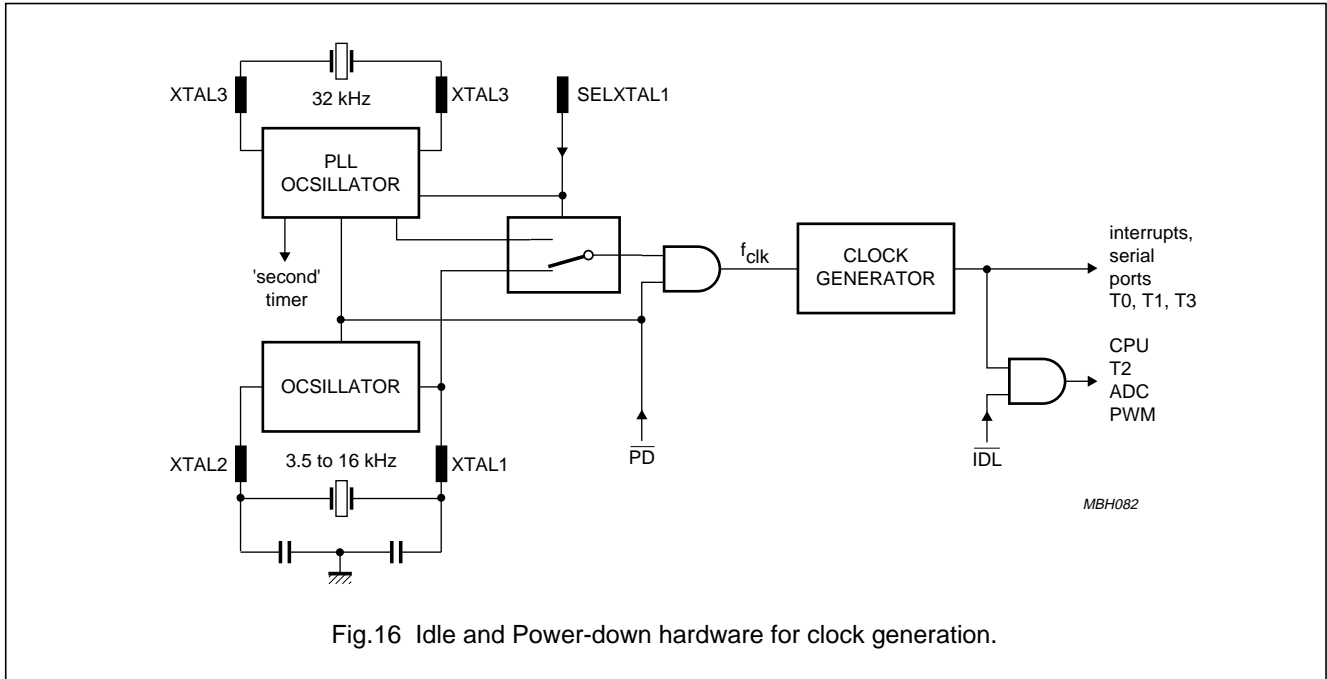

Fig.15 Wake-up by interrupt.

8-bit microcontroller

P8xC557E8



15.5 Power Control Register (PCON)

PCON is not bit addressable and the value after reset is 00H.

Table 70 Power Control Register (address 87H)

7	6	5	4	3	2	1	0
SMOD	ARD	RFI	WLE	GF1	GF0	PD	IDL

Table 71 Description of PCON bits

BIT	SYMBOL	DESCRIPTION
7	SMOD	<b>Double Baud rate.</b> When set to logic 1 the baud rate is doubled when the serial port SIO0 is being used in Modes 1, 2 and 3.
6	ARD	<b>AUX-RAM disable.</b> When set to logic 1 the internal 1792 bytes AUX-RAM is disabled, so that all MOVX-Instructions access the external Data Memory - as it is with the standard 80C51.
5	RFI	<b>RFI-Reduction Mode.</b> When set to HIGH the toggling of ALE pin is prohibited. This bit is cleared on reset and can be set and cleared by software. When set, ALE pin will be pulled down internally, switching an external address latch to a quiet state. See also Sections 2.1 and 6.2.
4	WLE	<b>Watchdog Load Enable.</b> This flag must be set by software prior to loading T3 (Watchdog Timer). It is cleared when T3 is loaded.
3	GF1	<b>General purpose flag bits.</b>
2	GF0	
1	PD	<b>Power-down mode select.</b> Setting this bit activates Power-down mode. It can only be set if input $\bar{E}W$ is HIGH.
0	IDL	<b>Idle mode select.</b> Setting this bit activates the Idle mode.

## 8-bit microcontroller

## P8xC557E8

**16 OSCILLATOR CIRCUITS****16.1 XTAL1; XTAL2 oscillator: standard 80C51**

The XTAL1; XTAL2 oscillator: standard 80C51 is selected when input SELXTAL1 = 1. The oscillator circuit is a single-stage inverting amplifier in a Pierce oscillator configuration. The circuitry between pins XTAL1 and XTAL2 is basically an inverter biased to the transfer point. Either a crystal or ceramic resonator can be used as the feedback element to complete the oscillator circuitry. Both are operated in parallel resonance.

XTAL1 is the high gain amplifier input, and XTAL2 is the output; see Fig.17. To drive the P8xC557E8 externally, XTAL1 is driven from an external source and XTAL2 is left open-circuit; see Fig.18.

When the 'XTAL1; XTAL2 oscillator' is selected the 'XTAL3; XTAL4 oscillator' is halted; pins XTAL3 and XTAL4 must not be connected.

**16.2 XTAL3; XTAL4 oscillator: 32 kHz PLL oscillator (with Seconds timer)**

The XTAL3; XTAL4 oscillator: 32 kHz oscillator and the Phase Locked Loop (PLL) are selected when SELXTAL1 = 0 (XTAL1; XTAL2 oscillator is halted). In this case pin XTAL2 is kept floating.

**16.2.1 32 KHZ OSCILLATOR**

The 32 kHz oscillator consists of an inverter, which forms a Pierce oscillator with the on-chip components C1, C2, R<sub>f</sub> and an external crystal of 32768 Hz. The inverter is switched to 3-state and pin XTAL3 is pulled to V<sub>SS</sub>:

- During Power-down mode, when RUN32 (PLLCON.7) = 0
- During reset, RSTIN = 1
- When the XTAL1; XTAL2 oscillator is selected (SELXTAL1 = 1).

**16.2.2 PLL CURRENT CONTROLLED OSCILLATOR**

A Current Controlled Oscillator (CCO) generates a clock frequency f<sub>CCO</sub> of approximately 32, 38, 44 or 50 MHz. This CCO is controlled by the PLL, with the 32 kHz oscillator as the reference clock.

The system clock frequency f<sub>clk</sub> is derived from f<sub>CCO</sub> and can be varied under software control by changing the contents of the PLL Control Register (PLLCON) bits FSEL.4 to FSEL.0. The CCO frequency f<sub>CCO</sub> can be changed via the PLLCON bits FSEL.1 and FSEL.0 and the maximum locking time is 10 ms (this parameter is characterized). During the stabilization phase, no time critical routines should be executed.

Changing f<sub>clk</sub> has to be done in two steps:

- From **high** to **low** frequencies; first change FSEL.4 to FSEL.2, then FSEL.1 to FSEL.0
- From **low** to **high** frequencies; first change FSEL.1 to FSEL.0 only, and after a stabilization phase of 10 ms, change FSEL.4 to FSEL.2.

If only FSEL.4 to FSEL.2 is changed, and FSEL.1 to FSEL.0 not, then it takes approximately 1 μs until the new frequency is available. The frequency selection is shown in Table 73.

**16.2.3 PLL CONTROL REGISTER (PLLCON)**

PLLCON is a Special Function Register, which can be read and written by software. It contains the control bits:

- to select the system clock frequencies (f<sub>clk</sub>)
- the seconds interrupt flag (SECINT)
- to enable the seconds interrupt flag (ENSECI)
- the RUN32 bit, which defines if during Power-down mode the 32 kHz oscillator is halted or not.

PLLCON is initialized to 0DH upon reset (RSTIN = 1) or Watchdog Timer overflow. PLLCON = 0DH corresponds to a system clock frequency f<sub>clk</sub> = 11.01 MHz.



8-bit microcontroller

P8xC557E8

**Table 72** PLL Control Register (address F9H)

7	6	5	4	3	2	1	0
RUN32	ENSECI	SECINT	FSEL.4	FSEL.3	FSEL.2	FSEL.1	FSEL.0

**Table 73** Description of PLLCON bits

BIT	SYMBOL	DESCRIPTION
7	RUN32	If RUN32 = 0, then the 32 kHz oscillator is halted during Power-down mode. If RUN32 = 1, then the 32 kHz oscillator remains active during Power-down mode.
6	ENSECI	Enable the seconds interrupt; enabling $\overline{\text{INT1}}$ is also required.
5	SECINT	Seconds interrupt requested by an overflow of the seconds timer (which occurs every second) or via writing a logic 1 to this bit. SECINT can only be cleared by writing a logic 0 to this bit.
4 to 0	FSEL.4 to FSEL.0	System clock frequency selection bits; see Table 74.

**Table 74** System clock frequency ( $f_{\text{clk}}$ ) selection

Other combinations than mentioned in this table, are reserved and may not be selected. This allows to generate the standard baudrates 19200, 9600, 4800, 2400 and 1200 Baud, when using the UART and Timer 1.

FSEL.4	FSEL.3	FSEL.2	FSEL.1	FSEL.0	$f_{\text{clk}}$ (MHz)
1	0	0	1	1	3.93
0	1	1	1	1	7.86
0	1	0	1	1	15.73
1	0	0	1	0	4.72
0	1	1	1	0	9.44
1	0	0	0	1	5.51
0	1	1	0	1	11.01
1	0	0	0	0	6.29
0	1	1	0	0	12.58

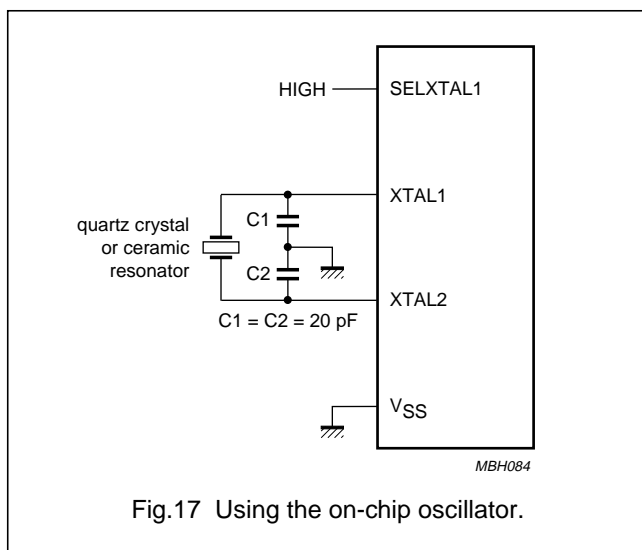

Fig.17 Using the on-chip oscillator.

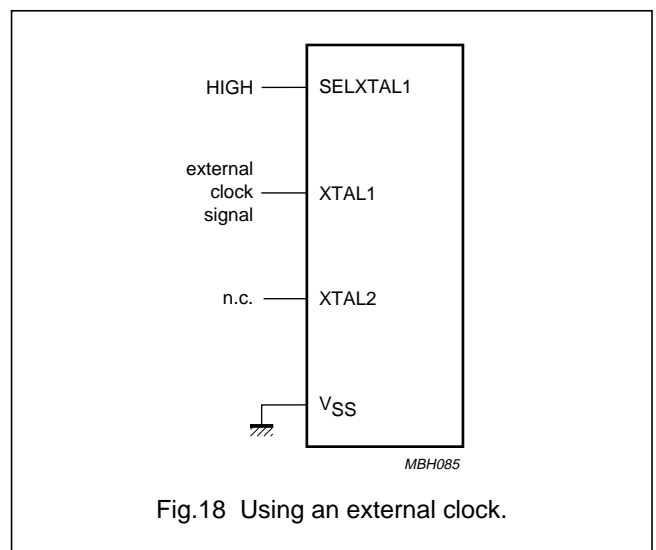

Fig.18 Using an external clock.

# 8-bit microcontroller

# P8xC557E8

## 16.2.4 SECONDS TIMER

This counter provides an overflow signal every second, when the 32 kHz oscillator is running. The overflow output sets the interrupt flag SECINT. This interrupt can be disabled/enabled by ENSECI. If SECINT is enabled, it is logically ORed with INT1 (External interrupt 1). The 'seconds' interrupt and INT1 therefore share the same priority and vector. The software has to check both flags SECINT (PLLCON.5) and IE1 (TCON.3) to distinguish between the two interrupt sources. SECINT can only be cleared via writing a logic 0 to this bit.

The external interrupts INT0, INT1 or the seconds interrupt can wake-up the PLL oscillator and the microcontroller as described in Chapter 15.3. For a wake-up via INT1 or seconds interrupt, IE1 must be enabled and level-sensitive.

A further function of the seconds timer is to control the start-up timing of the microcontroller after reset or after wake-up from Power-down.

It controls the stretching of the reset pulse to the microcontroller and controls releasing the system clock to the microcontroller. A RSTIN signal of 1  $\mu$ s at minimum will reset the microcontroller.

- In the even of reset or wake-up with halted 32 kHz oscillator: from RSTIN falling edge or wake-up interrupt it takes 560 ms at maximum for the start-up of the 32 kHz oscillator itself and the stabilization of the PLLs.
- In the event of wake-up with running 32 kHz oscillator: from wake-up interrupt it takes about 10 ms for the stabilization of the PLLs.

After this start-up time, the microcontroller is supplied with the system clock and - in case of a reset - the internally stretched reset signal overlaps about 45  $\mu$ s, to guarantee a proper initialization of the microcontroller.

For further information refer to Chapter 15.

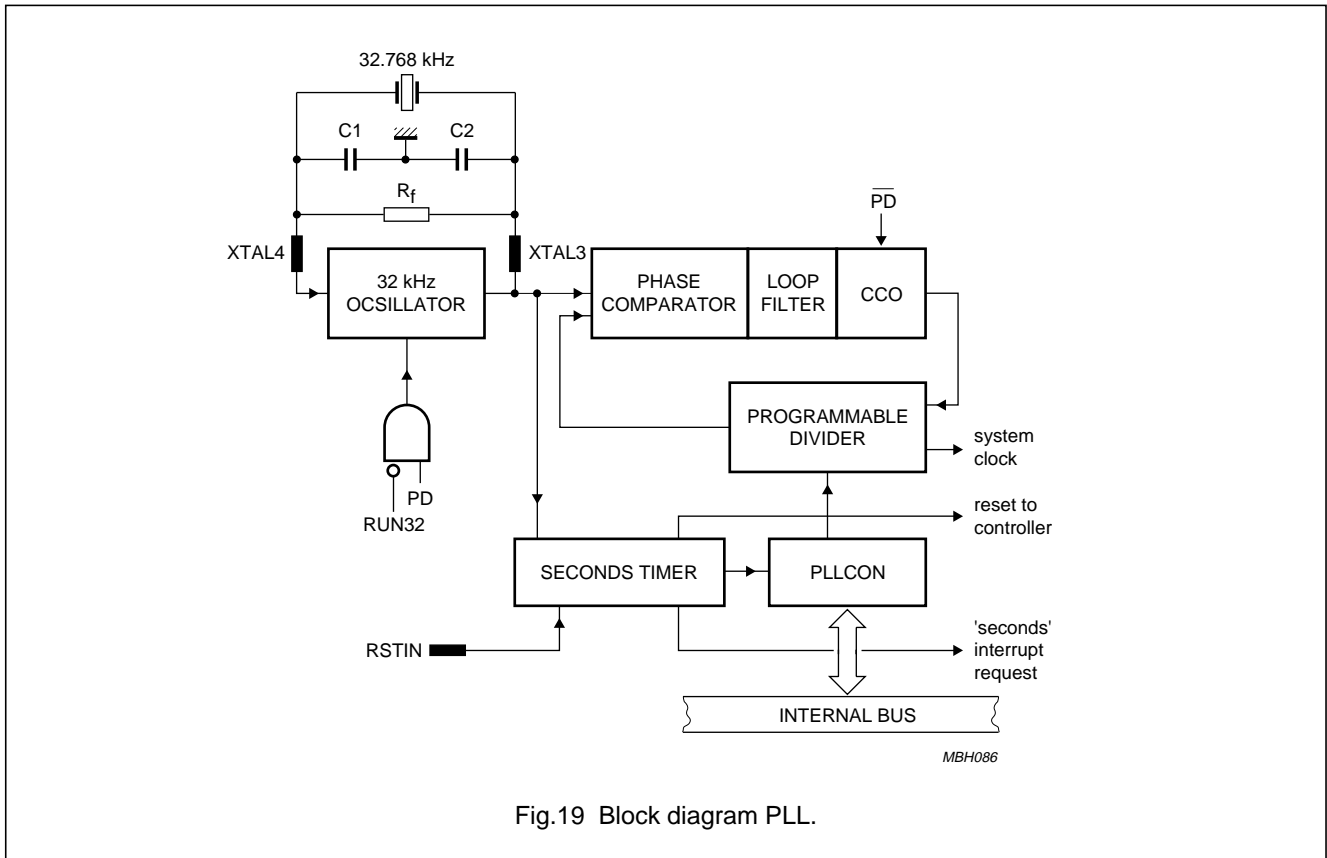

Fig.19 Block diagram PLL.

8-bit microcontroller

P8xC557E8

17 RESET CIRCUITRY

The reset input pin RSTIN is connected to a Schmitt Trigger for noise reduction (see Fig.20). If the HF oscillator is selected, a reset is accomplished by holding the RSTIN pin HIGH for at least 2 machine cycles (24 system clock periods). If the PLL oscillator is selected the RSTIN pulse must have a width of at least 1  $\mu$ s, independent of the 32 kHz-oscillator running or not (see PLL description). The CPU responds by executing an internal reset. The RSTOUT pin represents the signal resetting the CPU and can be used to reset peripheral devices.

The RSTOUT level also could be high due to a Watchdog timer overflow. The length of the output pulse from T3 is three machine cycles. A pulse of such short duration is necessary in order to recover from a processor or system fault as fast as possible. During reset, ALE and PSEN output a HIGH level. In order to perform a correct reset, this level must not be affected by external elements.

A reset leaves the internal registers as shown in Chapter 18. The internal RAM is not affected by reset. At power-on, the RAM content is indeterminate.

17.1 Power-on-reset

An automatic reset can be obtained by switching on  $V_{DD}$ , if the RSTIN pin is connected to  $V_{DD}$  via a capacitor, as shown in Figure 21. If the HF oscillator is selected the  $V_{DD}$  rise time must not exceed 10 ms and the capacitor should be at least 2.2  $\mu$ F. The decrease of the RSTIN pin voltage depends on the capacitor and the internal resistor  $R_{RST}$ . That voltage must remain above the lower threshold for at minimum the HF oscillator start-up time plus 2 machine cycles. If the PLL oscillator is selected, a 0.1  $\mu$ F capacitor is sufficient to obtain an automatic reset.

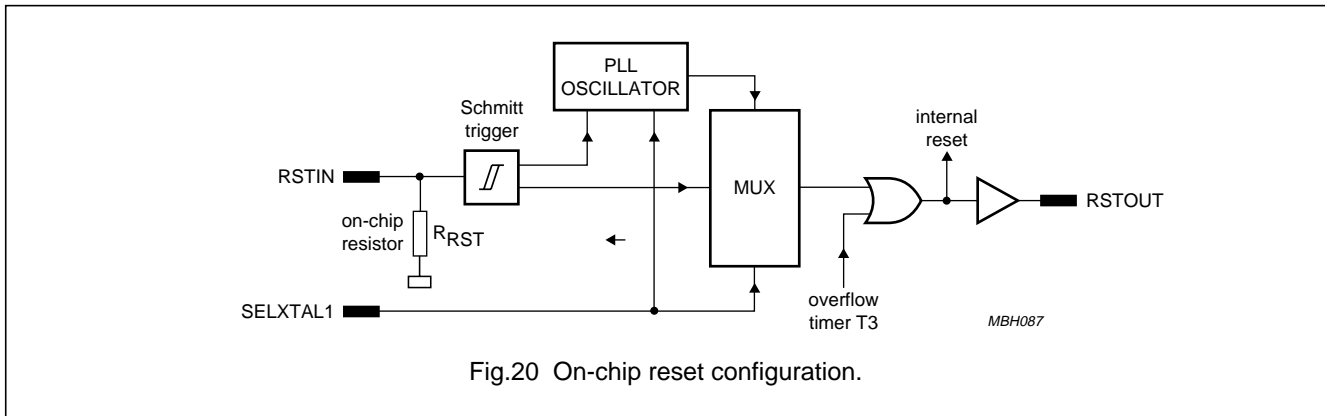

Fig.20 On-chip reset configuration.

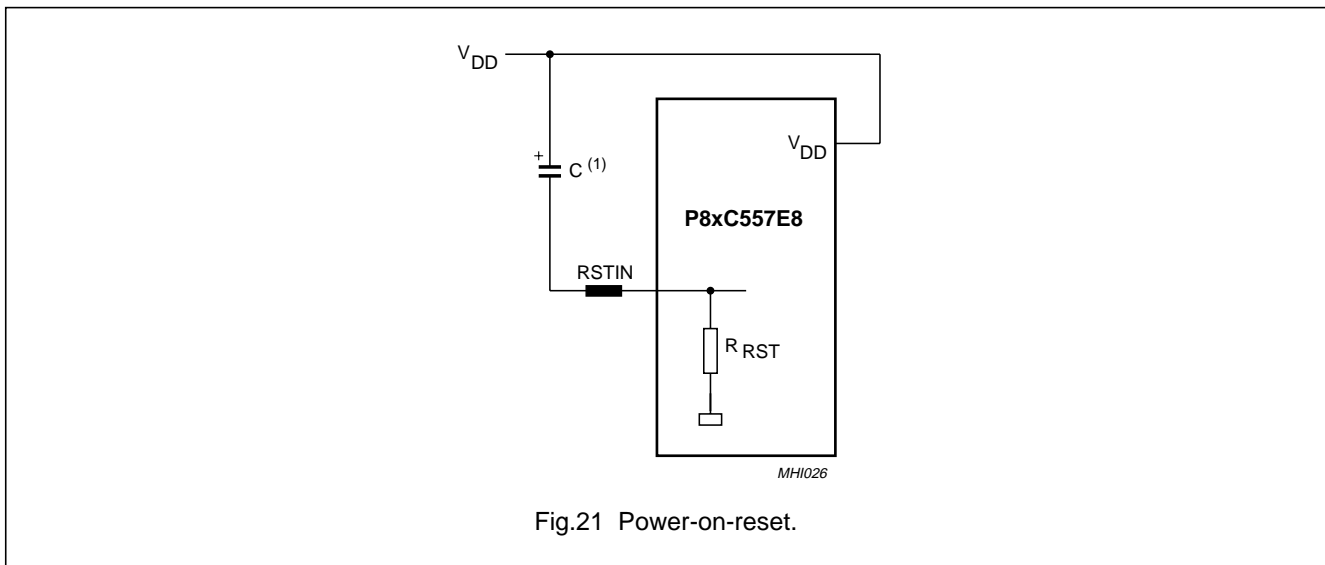

Fig.21 Power-on-reset.

## 8-bit microcontroller

## P8xC557E8

**18 SPECIAL FUNCTION REGISTERS OVERVIEW**

The P8xC557E8 has 67 SFRs available to the user.

ADDRESS (HEX)	NAME	RESET VALUE (B)	FUNCTION
FF	T3 <sup>(1)</sup>	XXXX0000	Watchdog Timer
FE	PWMP <sup>(1)</sup>	00000000	Prescaler Frequency Control Register
FD	PWM1 <sup>(1)</sup>	00000000	Pulse Width Register 1
FC	PWM0 <sup>(1)</sup>	00000000	Pulse Width Register 0
FA	XRAMP <sup>(1)</sup>	XXXXX000	AUX-RAM Page Register
F9	PLLCON <sup>(1)</sup>	00001101	PLL Control Register
F8	IP1 <sup>(1)</sup>	00000000	Interrupt Priority Register 1
F7	ADRS <sup>H</sup> <sup>(1)</sup>	000000XX	ADC Result Register High Byte
F6	ADRSL7	XXXXXXXX	ADC Result Register Low Byte
F0	B <sup>(2)</sup>	00000000	B Register
EF	RTE <sup>(2)</sup>	00000000	Reset/Toggle Enable Register
EE	STE <sup>(2)</sup>	11000000	Set Enable Register
ED	TMH2 <sup>(2)</sup>	00000000	T2 Register High Byte
EC	TML2 <sup>(2)</sup>	00000000	T2 Register Low Byte
EB	CTCON <sup>(2)</sup>	00000000	Capture Control Register
EA	TM2CON <sup>(2)</sup>	00000000	T2 Control Register
E8	IEN1 <sup>(2)</sup>	00000000	Interrupt Enable Register 1
E7	ADPSS	00000000	ADC Input Port Scan-Select Register
E6	ADRSL6	XXXXXXXX	ADC Result Register Low Byte
E0	ACC <sup>(2)</sup>	00000000	Accumulator
DB	S1ADR	XXXXXXXX	Address Register
DA	S1DAT	XXXXXXXX	Data Shift Register
D9	S1STA	00001100	Serial Status Register
D8	S1CON	00000000	The Serial Control Register
D7	ADCON	XX000000	ADC Control Register
D6	ADRSL5	XXXXXXXX	ADC Result Register Low Byte
D0	PSW <sup>(2)</sup>	00000000	Program Status Word
CF	CTH3	XXXXXXXX	T2 Capture Register 3 High Byte
CE	CTH2	XXXXXXXX	T2 Capture Register 2 High Byte
CD	CTH1	XXXXXXXX	T2 Capture Register 1 High Byte
CC	CTH0	XXXXXXXX	T2 Capture Register 0 High Byte
CB	CMH2	00000000	T2 Compare Register 2 High Byte
CA	CMH1	00000000	T2 Compare Register 1 High Byte
C9	CMH0	00000000	T2 Compare Register 0 High Byte
C8	TM2IR <sup>(2)</sup>	00000000	Interrupt Flag Register
C7	P5 <sup>(1)</sup>	11111111	Digital Input Port Register
C6	ADRSL4	XXXXXXXX	ADC Result Register Low Byte
C0	P4 <sup>(1)(2)</sup>	11111111	Digital Input Port Register

## 8-bit microcontroller

## P8xC557E8

ADDRESS (HEX)	NAME	RESET VALUE (B)	FUNCTION
B8	IP0 <sup>(2)</sup>	XXX00000	Interrupt Priority Register 0
B6	ADRSL3	XXXXXXXX	ADC Result Register Low Byte
B0	P3 <sup>(1)(2)</sup>	1111 1111	Digital Input Port Register
AF	CTL3 <sup>(2)</sup>	XXXXXXXX	T2 Capture Register 3 Low Byte
AE	CTL2 <sup>(2)</sup>	XXXXXXXX	T2 Capture Register 2 Low Byte
AD	CTL1 <sup>(2)</sup>	XXXXXXXX	T2 Capture Register 1 Low Byte
AC	CTL0 <sup>(2)</sup>	XXXXXXXX	T2 Capture Register 0 Low Byte
AB	CML2 <sup>(2)</sup>	00000000	T2 Compare Register 2 Low Byte
AA	CML1 <sup>(2)</sup>	00000000	T2 Compare Register 1 Low Byte
A9	CML0 <sup>(2)</sup>	00000000	T2 Compare Register 0 Low Byte
A8	IEN0 <sup>(2)</sup>	00000000	Interrupt Enable Register 0
A6	ADRSL2	XXXXXXXX	ADC Result Register Low Byte
A0	P2	1111 1111	Digital Input Port Register
99	S0BUF <sup>(1)</sup>	XXXXXXXX	Serial Data Buffer Register 0
98	S0CON <sup>(1)</sup>	00000000	Serial Port Control Register 0
96	ADRSL1	XXXXXXXX	ADC Result Register Low Byte
90	P1	1111 1111	Digital Input Port Register
8D	TH1	00000000	Timer 1 High byte
8C	TH0	00000000	Timer 0 High byte
8B	TL1	00000000	Timer 1 Low byte
8A	TL0	00000000	Timer 0 Low byte
89	TMOD	XX00XX00	Timer 0 and 1 Mode Control Register
88	TCON <sup>(2)</sup>	0000X000	Timer 0 and 1 Control/External Interrupt Control Register
87	PCON	XXXX0000	Power Control Register
86	ADRSL0	XXXXXXXX	ADC Result Register Low Byte
83	DPH	00000000	Data Pointer High byte
82	DPL	00000000	Data Pointer Low byte
81	SP	00000111	Stack Pointer
80	P0	1111 1111	Digital Input Port Register

**Notes**

1. P8xC557E8 specific SFRs.
2. Bit addressable register.

## 8-bit microcontroller

## P8xC557E8

**19 INSTRUCTION SET**

The P8xC557E8 uses the powerful instruction set of the PCB80C51. It consists of 49 single byte, 45 two byte and 17 three byte instructions. Using a 16 MHz crystal, 64 of the instructions are executed in 0.75  $\mu$ s, 45 in 1.5  $\mu$ s and the multiply, divide instructions in 3  $\mu$ s.

A summary of the instruction set is given in Tables 76, 77, 78, 79 and 80.

The P8xC557E8 has additional Special Function Registers to control the on-chip peripherals.

**19.1 Addressing modes**

Most instructions have a 'destination, source' field that specifies the data type, addressing modes and operands involved. For all these instructions, except for MOVs, the destination operand is also the source operand (e.g. ADD A,R7).

There are five kinds of addressing modes:

- Register Addressing
  - R0 to R7 (4 banks)
  - A,B,C (bit), AB (2 bytes), DPTR (double byte)
- Direct Addressing
  - lower 128 bytes of internal main RAM (including the four R0 to R7 register banks)
  - Special Function Registers
  - 128 bits in a subset of the internal main RAM
  - 128 bits in a subset of the Special Function Registers
- Register-Indirect Addressing
  - internal main RAM (@R0, @R1, @SP [PUSH/POP])
  - internal auxiliary RAM (@R0, @R1, @DPTR)
  - external Data Memory (@R0, @R1, @DPTR)
- Immediate Addressing
  - Program Memory (in-code 8 bit or 16 bit constant)
- Base-Register-plus-Index-Register-Indirect Addressing
  - Program Memory look-up table (@DPTR+A, @PC+A).

The first three addressing modes are usable for destination operands.

**19.2 80C51 family instruction set****Table 75** Instructions that affect flag settings; note 1

INSTRUCTION	FLAG <sup>(2)</sup>		
	C	OV	AC
ADD	X	X	X
ADDC	X	X	X
SUBB	X	X	X
MUL	0	X	
DIV	0	X	
DA	X	X	
RRC	X		
RLC	X		
SETB C	1		
CLR C	0		
CPL C	X		
ANL C, bit	X		
ANL C,/bit	X		
ORL C, bit	X		
ORL C,/bit	X		
MOV C, bit	X		
CJNE	X		

**Note**

1. Note that operations on SFR byte address 208 or bit addresses 209 to 215 (i.e. the PSW or bits in the PSW) will also affect flag settings.
2. X = don't care.

## 8-bit microcontroller

## P8xC557E8

## 19.3 Instruction set description

For the description of the **Data Addressing Modes** and **Hexadecimal opcode cross-reference** see Table 80.

**Table 76** Instruction set description: Arithmetic operations

MNEMONIC	DESCRIPTION	BYTES	CYCLES	OPCODE (HEX)
<b>Arithmetic operations</b>				
ADD A,Rr	Add register to A	1	1	2*
ADD A,direct	Add direct byte to A	2	1	25
ADD A,@Ri	Add indirect RAM to A	1	1	26, 27
ADD A,#data	Add immediate data to A	2	1	24
ADDC A,Rr	Add register to A with carry flag	1	1	3*
ADDC A,direct	Add direct byte to A with carry flag	2	1	35
ADDC A,@Ri	Add indirect RAM to A with carry flag	1	1	36, 37
ADDC A,#data	Add immediate data to A with carry flag	2	1	34
SUBB A,Rr	Subtract register from A with borrow	1	1	9*
SUBB A,direct	Subtract direct byte from A with borrow	2	1	95
SUBB A,@Ri	Subtract indirect RAM from A with borrow	1	1	96, 97
SUBB A,#data	Subtract immediate data from A with borrow	2	1	94
INC A	Increment A	1	1	04
INC Rr	Increment register	1	1	0*
INC direct	Increment direct byte	2	1	05
INC @Ri	Increment indirect RAM	1	1	06, 07
DEC A	Decrement A	1	1	14
DEC Rr	Decrement register	1	1	1*
DEC direct	Decrement direct byte	2	1	15
DEC @Ri	Decrement indirect RAM	1	1	16, 17
INC DPTR	Increment data pointer	1	2	A3
MUL AB	Multiply A and B	1	4	A4
DIV AB	Divide A by B	1	4	84
DA A	Decimal adjust A	1	1	D4

## 8-bit microcontroller

## P8xC557E8

**Table 77** Instruction set description: Logic operations

MNEMONIC		DESCRIPTION	BYTES	CYCLES	OPCODE (HEX)
<b>Logic operations</b>					
ANL	A,Rr	AND register to A	1	1	5*
ANL	A,direct	AND direct byte to A	2	1	55
ANL	A,@Ri	AND indirect RAM to A	1	1	56, 57
ANL	A,#data	AND immediate data to A	2	1	54
ANL	direct,A	AND A to direct byte	2	1	52
ANL	direct,#data	AND immediate data to direct byte	3	2	53
ORL	A,Rr	OR register to A	1	1	4*
ORL	A,direct	OR direct byte to A	2	1	45
ORL	A,@Ri	OR indirect RAM to A	1	1	46, 47
ORL	A,#data	OR immediate data to A	2	1	44
ORL	direct,A	OR A to direct byte	2	1	42
ORL	direct,#data	OR immediate data to direct byte	3	2	43
XRL	A,Rr	Exclusive-OR register to A	1	1	6*
XRL	A,direct	Exclusive-OR direct byte to A	2	1	65
XRL	A,@Ri	Exclusive-OR indirect RAM to A	1	1	66, 67
XRL	A,#data	Exclusive-OR immediate data to A	2	1	64
XRL	direct,A	Exclusive-OR A to direct byte	2	1	62
XRL	direct,#data	Exclusive-OR immediate data to direct byte	3	2	63
CLR	A	Clear A	1	1	E4
CPL	A	Complement A	1	1	F4
RL	A	Rotate A left	1	1	23
RLC	A	Rotate A left through the carry flag	1	1	33
RR	A	Rotate A right	1	1	03
RRC	A	Rotate A right through the carry flag	1	1	13
SWAP	A	Swap nibbles within A	1	1	C4



## 8-bit microcontroller

## P8xC557E8

**Table 78** Instruction set description: Data transfer

MNEMONIC	DESCRIPTION	BYTES	CYCLES	OPCODE (HEX)
<b>Data transfer</b>				
MOV A,Rr	Move register to A	1	1	E*
MOV A,direct (note 1)	Move direct byte to A	2	1	E5
MOV A,@Ri	Move indirect RAM to A	1	1	E6, E7
MOV A,#data	Move immediate data to A	2	1	74
MOV Rr,A	Move A to register	1	1	F*
MOV Rr,direct	Move direct byte to register	2	2	A*
MOV Rr,#data	Move immediate data to register	2	1	7*
MOV direct,A	Move A to direct byte	2	1	F5
MOV direct,Rr	Move register to direct byte	2	2	8*
MOV direct,direct	Move direct byte to direct	3	2	85
MOV direct,@Ri	Move indirect RAM to direct byte	2	2	86, 87
MOV direct,#data	Move immediate data to direct byte	3	2	75
MOV @Ri,A	Move A to indirect RAM	1	1	F6, F7
MOV @Ri,direct	Move direct byte to indirect RAM	2	2	A6, A7
MOV @Ri,#data	Move immediate data to indirect RAM	2	1	76, 77
MOV DPTR,#data 16	Load data pointer with a 16-bit constant	3	2	90
MOVC A,@A+DPTR	Move code byte relative to DPTR to A	1	2	93
MOVC A,@A+PC	Move code byte relative to PC to A	1	2	83
MOVX A,@Ri	Move external RAM (8-bit address) to A	1	2	E2, E3
MOVX A,@DPTR	Move external RAM (16-bit address) to A	1	2	E0
MOVX @Ri,A	Move A to external RAM (8-bit address)	1	2	F2, F3
MOVX @DPTR,A	Move A to external RAM (16-bit address)	1	2	F0
PUSH direct	Push direct byte onto stack	2	2	C0
POP direct	Pop direct byte from stack	2	2	D0
XCH A,Rr	Exchange register with A	1	1	C*
XCH A,direct	Exchange direct byte with A	2	1	C5
XCH A,@Ri	Exchange indirect RAM with A	1	1	C6, C7
XCHD A,@Ri	Exchange LOW-order digit indirect RAM with A	1	1	D6, D7

**Note**

1. MOV A,ACC is not permitted.

## 8-bit microcontroller

## P8xC557E8

**Table 79** Instruction set description: Boolean variable manipulation, Program and machine control

MNEMONIC	DESCRIPTION	BYTES	CYCLES	OPCODE (HEX)
<b>Boolean variable manipulation</b>				
CLR C	Clear carry flag	1	1	C3
CLR bit	Clear direct bit	2	1	C2
SETB C	Set carry flag	1	1	D3
SETB bit	Set direct bit	2	1	D2
CPL C	Complement carry flag	1	1	B3
CPL bit	Complement direct bit	2	1	B2
ANL C,bit	AND direct bit to carry flag	2	2	82
ANL C,/bit	AND complement of direct bit to carry flag	2	2	B0
ORL C,bit	OR direct bit to carry flag	2	2	72
ORL C,/bit	OR complement of direct bit to carry flag	2	2	A0
MOV C,bit	Move direct bit to carry flag	2	1	A2
MOV bit,C	Move carry flag to direct bit	2	2	92
<b>Program and machine control</b>				
ACALL addr11	Absolute subroutine call	2	2	•1
LCALL addr16	Long subroutine call	3	2	12
RET	Return from subroutine	1	2	22
RETI	Return from interrupt	1	2	32
AJMP addr11	Absolute jump	2	2	♦1
LJMP addr16	Long jump	3	2	02
SJMP rel	Short jump (relative address)	2	2	80
JMP @A+DPTR	Jump indirect relative to the DPTR	1	2	73
JZ rel	Jump if A is zero	2	2	60
JNZ rel	Jump if A is not zero	2	2	70
JC rel	Jump if carry flag is set	2	2	40
JNC rel	Jump if carry flag is not set	2	2	50
JB bit,rel	Jump if direct bit is set	3	2	20
JNB bit,rel	Jump if direct bit is not set	3	2	30
JBC bit,rel	Jump if direct bit is set and clear bit	3	2	10
CJNE A,direct,rel	Compare direct to A and jump if not equal	3	2	B5
CJNE A,#data,rel	Compare immediate to A and jump if not equal	3	2	B4
CJNE Rr,#data,rel	Compare immediate to register and jump if not equal	3	2	B*
CJNE @Ri,#data,rel	Compare immediate to indirect and jump if not equal	3	2	B6, B7
DJNZ Rr,rel	Decrement register and jump if not zero	2	2	D*
DJNZ direct,rel	Decrement direct and jump if not zero	3	2	D5
NOP	No operation	1	1	00

## 8-bit microcontroller

## P8xC557E8

**Table 80** Description of the mnemonics in the Instruction set

MNEMONIC	DESCRIPTION
<b>Data addressing modes</b>	
Rr	Working register R0-R7.
direct	128 internal RAM locations and any special function register (SFR).
@Ri	Indirect internal RAM location addressed by register R0 or R1 of the actual register bank.
#data	8-bit constant included in instruction.
#data 16	16-bit constant included as bytes 2 and 3 of instruction.
bit	Direct addressed bit in internal RAM or SFR.
addr16	16-bit destination address. Used by LCALL and LJMP. The branch will be anywhere within the 64 kbytes Program Memory address space.
addr11	11-bit destination address. Used by ACALL and AJMP. The branch will be within the same 2 kbytes page of Program Memory as the first byte of the following instruction.
rel	Signed (two's complement) 8-bit offset byte. Used by SJMP and all conditional jumps. Range is -128 to +127 bytes relative to first byte of the following instruction.
<b>Hexadecimal opcode cross-reference</b>	
*	8, 9, A, B, C, D, E, F.
•	1, 3, 5, 7, 9, B, D, F.
◆	0, 2, 4, 6, 8, A, C, E.

## 8-bit microcontroller

P8XC557E8

Table 81 Instruction map

↓	First hexadecimal character of opcode							← Second hexadecimal character of opcode →									
	0	1	2	3	4	5	6	7	8	9	A	B	C	D	E	F	
0	NOP	AJMP addr11	LJMP addr16	RR A	INC A	INC direct	INC @Ri 0   1		INC Rr 0   1   2   3   4   5   6   7								
1	JBC bit,rel	ACALL addr11	LCALL addr16	RRC A	DEC A	DEC direct	DEC @Ri 0   1		DEC Rr 0   1   2   3   4   5   6   7								
2	JB bit,rel	AJMP addr11	RET	RL A	ADD A,#data	ADD A,direct	ADD A,@Ri 0   1		ADD A,Rr 0   1   2   3   4   5   6   7								
3	JNB bit,rel	ACALL addr11	RETI	RLC A	ADDC A,#data	ADDC A,direct	ADDC A,@Ri 0   1		ADDC A,Rr 0   1   2   3   4   5   6   7								
4	JC rel	AJMP addr11	ORL direct,A	ORL direct,#data	ORL A,#data	ORL A,direct	ORL A,@Ri 0   1		ORL A,Rr 0   1   2   3   4   5   6   7								
5	JNC rel	ACALL addr11	ANL direct,A	ANL direct,#data	ANL A,#data	ANL A,direct	ANL A,@Ri 0   1		ANL A,Rr 0   1   2   3   4   5   6   7								
6	JZ rel	AJMP addr11	XRL direct,A	XRL direct,#data	XRL A,#data	XRL A,direct	XRL A,@Ri 0   1		XRL A,Rr 0   1   2   3   4   5   6   7								
7	JNZ rel	ACALL addr11	ORL C,bit	JMP @A+DPTR	MOV A,#data	MOV direct,#data	MOV @Ri,#data 0   1		MOV Rr,#data 0   1   2   3   4   5   6   7								
8	SJMP rel	AJMP addr11	ANL C,bit	MOVC A,@A+PC	DIV AB	MOV direct,direct	MOV direct,@Ri 0   1		MOV direct,Rr 0   1   2   3   4   5   6   7								
9	MOV DTPR,#data16	ACALL addr11	MOV bit,C	MOVC A,@A+DPTR	SUBB A,#data	SUBB A,direct	SUBB A,@Ri 0   1		SUB A,Rr 0   1   2   3   4   5   6   7								
A	ORL C,/bit	AJMP addr11	MOV bit,C	INC DPTR	MUL AB		MOV @Ri,direct 0   1		MOV Rr,direct 0   1   2   3   4   5   6   7								
B	ANL C,/bit	ACALL addr11	CPL bit	CPL C	CJNE A,#data,rel	CJNE A,direct,rel	CJNE @Ri,#data,rel 0   1		CJNE Rr,#data,rel 0   1   2   3   4   5   6   7								
C	PUSH direct	AJMP addr11	CLR bit	CLR C	SWAP A	XCH A,direct	XCH A,@Ri 0   1		XCH A,Rr 0   1   2   3   4   5   6   7								
D	POP direct	ACALL addr11	SETB bit	SETB C	DA A	DJNZ direct,rel	XCHD A,@Ri 0   1		DJNZ Rr,rel 0   1   2   3   4   5   6   7								
E	MOVX A,@DTPR	AJMP addr11	MOVX A,@Ri 0   1		CLR A	MOV A,direct <sup>(1)</sup>	MOV A,@Ri 0   1		MOV A,Rr 0   1   2   3   4   5   6   7								
F	MOVX @DTPR,A	ACALL addr11	MOVX @Ri,A 0   1		CPL A	MOV direct,A	MOV @Ri,A 0   1		MOV Rr,A 0   1   2   3   4   5   6   7								

## Note

- MOV A, ACC is not a valid instruction.

## 8-bit microcontroller

## P8xC557E8

**20 LIMITING VALUES**

In accordance with the Absolute Maximum Rating System (IEC 134); note 1

SYMBOL	PARAMETER	MIN.	MAX.	UNIT
$V_{DD}$	voltage on $V_{DD}$ to $V_{SS}$ and SCL, SDA to $V_{SS}$	-0.5	+6.5	V
$V_I$	input voltage on: any other pin to $V_{SS}$ $\overline{EA}/V_{PP}$ to $V_{SS}$	-0.5 -0.5	$V_{DD} + 0.5$ +13	V V
$I_I, I_O$	input/output current on any I/O pin	-	$\pm 10$	mA
$P_{tot}$	total power dissipation (note 2)	-	1.0	W
$T_{stg}$	storage temperature range	-65	+150	°C
$T_{amb}$	operating ambient temperature range: P8xC557E8EFB	-40	+85	°C

**Notes**

1. The following applies to the Absolute Maximum Ratings:
  - a) Stresses above those listed under Absolute Maximum Ratings may cause permanent damage to the device. This is a stress rating only and functional operation of the device at these or any conditions other than those described in the Chapters 21 and 22 of this specification is not implied.
  - b) This product includes circuitry specifically designed for the protection of its internal devices from the damaging effect of excessive static charge. However, it is suggested that conventional precautions be taken to avoid applying greater than the rated maxima.
  - c) Parameters are valid over operating temperature range unless otherwise specified. All voltages are with respect to  $V_{SS}$  unless otherwise noted.
2. This value is based on the maximum allowable die temperature and the thermal resistance of the package, not on device power consumption.

## 8-bit microcontroller

## P8xC557E8

## 21 DC CHARACTERISTICS

$V_{DD} = 5\text{ V} \pm 10\%$ ;  $V_{SS} = 0\text{ V}$ ; all voltages with respect to  $V_{SS}$  unless otherwise specified;

$T_{amb} = -40\text{ to }+85\text{ }^{\circ}\text{C}$  for the **P8xC557E8EFB**;  $V_{DDA} = 5\text{ V} \pm 10\%$ ;  $V_{SSA} = 0\text{ V}$ .

SYMBOL	PARAMETER	CONDITIONS	MIN.	MAX.	UNIT
<b>Supply (digital part)</b>					
$V_{DD}$	supply voltage		4.5	5.5	V
$I_{DD}$	operating supply current	$V_{DD} = 5.5\text{ V}$ ; notes 1 and 2	–	40	mA
$I_{DD(ID)}$	supply current Idle mode	$V_{DD} = 5.5\text{ V}$ ; notes 1 and 3	–	12	mA
$I_{DD(PD)}$	supply current Power-down mode	$2\text{ V} < V_{DD} < V_{DDmax}$ ; note 4	–	100	$\mu\text{A}$
	supply current Power-down mode; 32 kHz/PLL operation	$V_{DD} = 5.5\text{ V}$ ; note 17	–	100	$\mu\text{A}$
<b>Inputs</b>					
$V_{IL}$	LOW level input voltage (except EA, SCL, SDA)		–0.5	$0.2V_{DD} - 0.15$	V
$V_{IL1}$	LOW level input voltage $\overline{EA}$		–0.5	$0.2V_{DD} - 0.35$	V
$V_{IL2}$	LOW level input voltage SCL and SDA; note 5		–0.5	$0.3V_{DD}$	V
$V_{IH}$	HIGH level input voltage (except XTAL1, RSTIN, SCL, SDA, ADEXS)		$0.2V_{DD} + 1.0$	$V_{DD} + 0.5$	V
$V_{IH1}$	HIGH level input voltage XTAL1, RSTIN, ADEXS		$0.7V_{DD} + 0.1$	$V_{DD} + 0.5$	V
$V_{IH2}$	HIGH level input voltage SCL and SDA; note 5		$0.7V_{DD}$	6.0	V
$I_{IL}$	LOW level input current Ports 1, 2, 3 and 4	$V_{IN} = 0.45\text{ V}$	–	–75	$\mu\text{A}$
$I_{TL}$	input current HIGH-to-LOW transition Ports 1, 2, 3 and 4	note 6	–	–750	$\mu\text{A}$
$I_{LI1}$	input leakage current Port 0, $\overline{EA}$ , ADEXS, $\overline{EW}$ , SELXTAL1	$0.45\text{ V} < V_I < V_{DD}$	–	$\pm 10$	$\mu\text{A}$
$I_{LI2}$	input leakage current SCL and SDA	$0\text{ V} < V_I < 6\text{ V}$ $0\text{ V} < V_{DD} < 5.5\text{ V}$	–	$\pm 10$	$\mu\text{A}$
$I_{LI3}$	input leakage current Port 5	$0.45\text{ V} < V_I < V_{DD}$	–	$\pm 1$	$\mu\text{A}$
<b>Outputs</b>					
$V_{OL}$	LOW level output voltage Ports 1, 2, 3 and 4	$I_{OL} = 1.6\text{ mA}$ ; note 7	–	0.45	V
$V_{OL1}$	LOW level output voltage Port 0, ALE, PSEN, PWM0, PWM1, RSTOUT	$I_{OL} = 3.2\text{ mA}$ ; note 7	–	0.45	V
$V_{OH}$	HIGH level output voltage Ports 1, 2, 3 and 4	$I_{OH} = -60\text{ }\mu\text{A}$	2.4	–	V
		$I_{OH} = -25\text{ }\mu\text{A}$	$0.75V_{DD}$	–	V
		$I_{OH} = -10\text{ }\mu\text{A}$	$0.9V_{DD}$	–	V
$V_{OH1}$	HIGH level output voltage Port 0 in external bus mode, ALE, PSEN, PWM0, PWM1, RSTOUT; note 8	$I_{OH} = -800\text{ }\mu\text{A}$	2.4	–	V
		$I_{OH} = -300\text{ }\mu\text{A}$	$0.75V_{DD}$	–	V
		$I_{OH} = -80\text{ }\mu\text{A}$	$0.9V_{DD}$	–	V

## 8-bit microcontroller

## P8xC557E8

SYMBOL	PARAMETER	CONDITIONS	MIN.	MAX.	UNIT
V <sub>HYS</sub>	hysteresis of Schmitt Trigger inputs SCL and SDA (Fast Mode)		0.05V <sub>DD</sub> <sup>(20)</sup>	–	V
R <sub>RST</sub>	RST pull-down resistor		50	150	kΩ
C <sub>I/O</sub>	I/O pin capacitance	test frequency = 1 MHz; T <sub>amb</sub> = 25 °C	–	10	pF
<b>Supply (analog part)</b>					
V <sub>DDA</sub>	supply voltage	V <sub>DDA</sub> = V <sub>DD</sub> ± 0.2 V	4.5	5.5	V
I <sub>DDA</sub>	supply current operating	Port 5 = 0 V to V <sub>DDA</sub> ; notes 1 and 2	–	1.2	mA
	supply current operating 32 kHz / PLL operation	Port 5 = 0 V to V <sub>DDA</sub> ; notes 17 and 18	–	7.2	mA
I <sub>DDA</sub> (ID)	supply current Idle mode	notes 1 and 3	–	70	μA
	supply current Idle mode 32 kHz / PLL operation	notes 17 and 18	–	6.0	mA
I <sub>DDA</sub> (PD)	supply current Power-down mode	2 V < V <sub>DD</sub> < V <sub>DD(max)</sub> ; note 4	–	50	μA
	supply current Power-down mode 32 kHz/PLL operation	V <sub>DD</sub> = 5.5 V; note 17	–	200	μA
<b>Analog inputs</b>					
V <sub>in(A)</sub>	analog input voltage		V <sub>SSA</sub> – 0.2	V <sub>DDA</sub> + 0.2	V
V <sub>ref(n)(A)</sub>	reference voltage		V <sub>SSA</sub> – 0.2	–	V
V <sub>ref(p)(A)</sub>			–	V <sub>DDA</sub> + 0.2	V
R <sub>REF</sub>	resistance between V <sub>ref(p)(A)</sub> and V <sub>ref(n)(A)</sub>		10	50	kΩ
C <sub>IA</sub>	analog input capacitance		–	15	pF
DL <sub>e</sub>	differential non-linearity	notes 9, 10 and 11	–	±1	LSB
IL <sub>e</sub>	integral non-linearity	notes 9 and 12	–	±2	LSB
OS <sub>e</sub>	offset error	notes 9 and 13	–	±2	LSB
G <sub>e</sub>	gain error	notes 9 and 14	–	±0.4	%
A <sub>e</sub>	absolute voltage error	notes 9 and 15	–	±3	LSB
M <sub>ctc</sub>	channel-to-channel matching		–	±1	LSB
C <sub>t</sub>	crosstalk between P5 inputs	0 to 100 kHz; note 16	–	–60	dB

## 8-bit microcontroller

## P8xC557E8

**Notes to the DC characteristics**

1. See Figs 22, 25 and 24 for  $I_{DD}$  test conditions.
2. The operating supply current is measured with all output pins disconnected; XTAL1 driven with  $t_r = t_f = 5\text{ns}$ ;  $V_{IL} = V_{SS} + 0.5\text{ V}$ ;  $V_{IH} = V_{DD} - 0.5\text{ V}$ ; XTAL2, XTAL3 not connected; Port 0 =  $\overline{EW} = SCL = SDA = SELXTAL1 = V_{DD}$ ;  $\overline{EA} = RSTIN = ADEXS = XTAL4 = V_{SS}$ .
3. The Idle mode supply current is measured with all output pins disconnected; XTAL1 driven with  $t_r = t_f = 5\text{ns}$ ;  $V_{IL} = V_{SS} + 0.5\text{ V}$ ;  $V_{IH} = V_{DD} - 0.5\text{ V}$ ; XTAL2, XTAL3 not connected;  $\overline{EA} = RSTIN = \text{Port } 0 = \overline{EW} = SCL = SDA = SELXTAL1 = V_{DD}$ ; ADEXS = XTAL4 =  $V_{SS}$ .
4. The Power-down current is measured with all output pins disconnected; XTAL2 not connected; Port 0 =  $\overline{EW} = SCL = SDA = SELXTAL1 = V_{DD}$ ;  $\overline{EA} = RSTIN = ADEXS = XTAL1 = XTAL4 = V_{SS}$ .
5. The input threshold voltage of SCL and SDA (SIO1) meets the I<sup>2</sup>C specification, so an input voltage below  $0.3 V_{DD}$  will be recognized as a logic 0 while an input voltage above  $0.7 V_{DD}$  will be recognized as a logic 1.
6. Pins of Ports 1, 2, 3 and 4 source a transition current when they are being externally driven from HIGH to LOW. The transition current reaches its maximum value when  $V_{IN}$  is approximately 2 V.
7. Capacitive loading on Ports 0 and 2 may cause spurious noise to be superimposed on the  $V_{OL}$  of ALE and Ports 1, 3 and 4. The noise is due to external bus capacitance discharging into the Port 0 and Port 2 pins when these pins make HIGH-to-LOW transitions during bus operations. In the worst cases (capacitive loading > 100pF), the noise pulse on the ALE pin may exceed 0.8 V. In such cases, it may be desirable to qualify ALE with a Schmitt Trigger, or use an address latch with a Schmitt Trigger STROBE input.
8. Capacitive loading on Ports 0 and 2 may cause the  $V_{OH}$  on ALE and  $\overline{PSEN}$  to momentarily fall below the  $0.9 V_{DD}$  specification when the address bits are stabilizing.
9.  $V_{ref(n)(A)} = 0\text{ V}$ ;  $V_{DDA} = 5.0\text{ V}$ ,  $V_{ref(p)(A)} = 5.12\text{ V}$ .  $V_{DD} = 5.0\text{ V}$ ,  $V_{SS} = 0\text{ V}$ , ADC is monotonic with no missing codes. Measurement by continuous conversion of  $V_{in(A)} = -20\text{ mV}$  to  $5.12\text{ V}$  in steps of  $0.5\text{ mV}$ , deriving parameters from collected conversion results of ADC. ADC prescaler programmed according to the actual oscillator frequency, resulting in a conversion time within the specified range for  $t_{ADC}$  (15 to  $50\text{ }\mu\text{s}$ ).
10. The differential non-linearity ( $D_{Le}$ ) is the difference between the actual step width and the ideal step width.
11. The ADC is monotonic; there are no missing codes.
12. The integral non-linearity ( $I_{Le}$ ) is the peak difference between the centre of the steps of the actual and the ideal transfer curve after appropriate adjustment of gain and offset error.
13. The offset error ( $OS_e$ ) is the absolute difference between the straight line which fits the actual transfer curve (after removing gain error), and a straight line which fits the ideal transfer curve. The offset error is constant at every point of the actual transfer curve.
14. The gain error ( $G_e$ ) is the relative difference in percent between the straight line fitting the actual transfer curve (after removing offset error), and the straight line which fits the ideal transfer curve. Gain error is constant at every point on the transfer curve.
15. The absolute voltage error ( $A_e$ ) is the maximum difference between the centre of the steps of the actual transfer curve of the non-calibrated ADC and the ideal transfer curve.
16. This should be considered when both analog and digital signals are simultaneously input to Port 5.
17. The supply current with 32 kHz oscillator running and PLL operation ( $SELXTAL1 = 0$ ) is measured with all output pins disconnected; XTAL4 driven with  $t_r = t_f = 5\text{ ns}$ ;  $V_{IL} = V_{SS} + 0.5\text{ V}$ ;  $V_{IH} = V_{DD} - 0.5\text{ V}$ ; XTAL2 not connected; Port 0 =  $\overline{EW} = SCL = SDA = V_{DD}$ ;  $\overline{EA} = RSTIN = ADEXS = SELXTAL\ 1 = XTAL1 = V_{SS}$ .
18. Not 100% tested; sum of  $I_{DDA(ID)}$  (PLL) and  $I_{DDA}$  (HF-Oscillator).
19. The parameter meets the I<sup>2</sup>C-bus specification for standard-mode and fast-mode devices.
20. Not 100% tested.



8-bit microcontroller

P8xC557E8

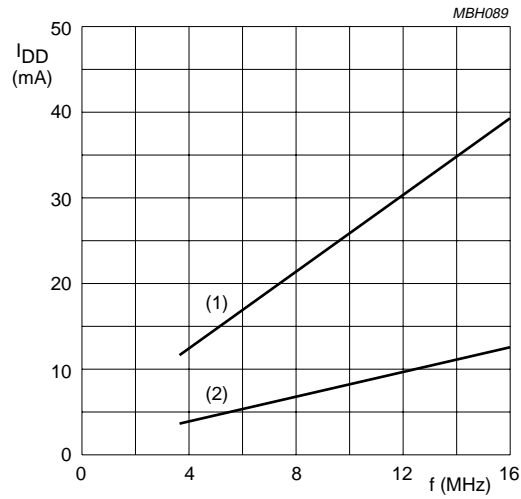

For P8xC557E8 at  $V_{DD} = 5.5$  V:

- (1) Maximum operating supply current ( $I_{DD}$ ).
- (2) Maximum supply current Idle mode ( $I_{DD(ID)}$ ).

Fig.22 Supply current ( $I_{DD}$ ) as a function of frequency at XTAL1 ( $f_{clk}$ ).

8-bit microcontroller

P8xC557E8

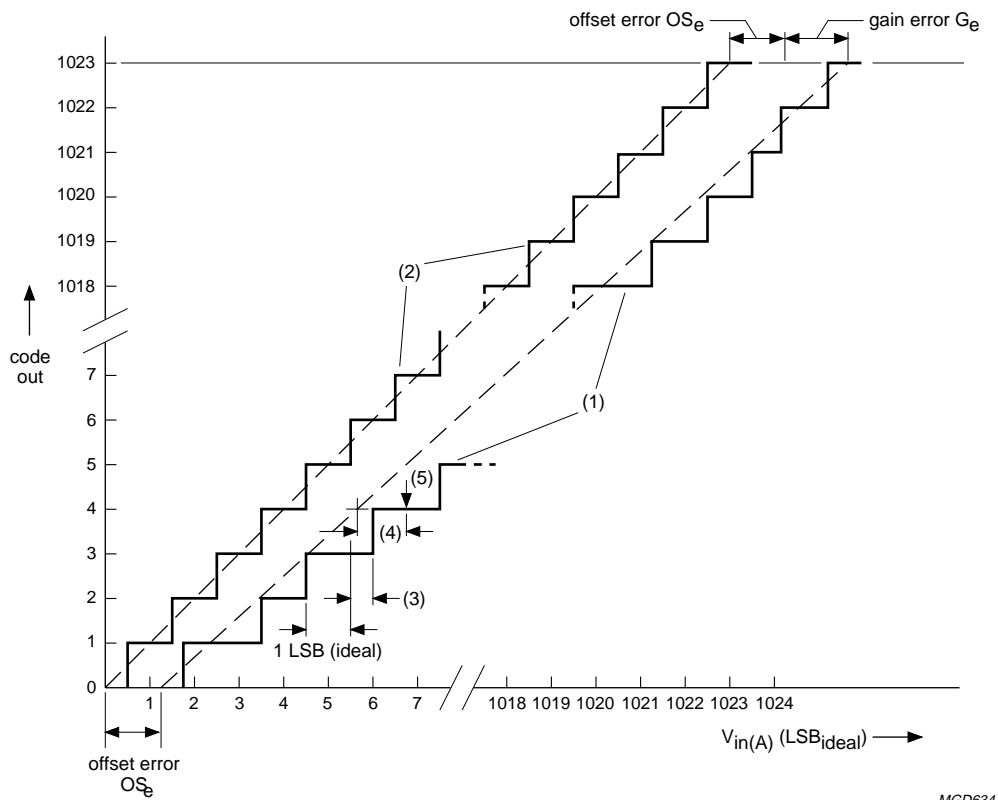

MGD634

$$1\text{LSB}_{\text{ideal}} = \frac{V_{\text{ref}(p)(A)} + V_{\text{ref}(n)(A)}}{1024}$$

- (1) Example of an actual transfer curve.
- (2) The ideal transfer curve.
- (3) Differential non-linearity (DL<sub>e</sub>).
- (4) Integral non-linearity (IL<sub>e</sub>).
- (5) Centre of a step of the actual transfer curve.

Fig.23 ADC conversion characteristic.

## 8-bit microcontroller

## P8xC557E8

**22 AC CHARACTERISTICS**

$V_{DD} = 5\text{ V} \pm 10\%$ ;  $V_{SS} = 0\text{ V}$ ;  $T_{amb} = -40\text{ }^{\circ}\text{C}$  to  $+85\text{ }^{\circ}\text{C}$ ;  $C_L = 100\text{ pF}$  for Port 0, ALE and  $\overline{\text{PSEN}}$ ;  $C_L = 80\text{ pF}$  for all other outputs unless otherwise specified;  $t_{clk(min)} = 1/f_{clk(max)}$  ( $f_{clk(max)}$  = maximum operating frequency);  $t_{clk(min)} = 63\text{ ns}$ .

SYMBOL	PARAMETER	$f_{clk} = 12\text{ MHz}$		$f_{clk} = 16\text{ MHz}$		VARIABLE CLOCK $f_{clk} = 3.5\text{ to }16\text{ MHz}$		UNIT
		MIN.	MAX.	MIN.	MAX.	MIN.	MAX.	
<b>External Program Memory; see Fig.27</b>								
$t_{LHLL}$	ALE pulse width	127	–	85	–	$2t_{clk} - 40$	–	ns
$t_{AVLL}$	address valid to ALE LOW	43	–	23	–	$t_{clk} - 40$	–	ns
$t_{LLAX}$	address hold after ALE LOW	53	–	33	–	$t_{clk} - 30$	–	ns
$t_{LLIV}$	ALE LOW to valid instruction in	–	234	–	150	–	$4t_{clk} - 100$	ns
$t_{LLPL}$	ALE LOW to $\overline{\text{PSEN}}$ LOW	53	–	33	–	$t_{clk} - 30$	–	ns
$t_{PLPH}$	$\overline{\text{PSEN}}$ pulse width	205	–	143	–	$3t_{clk} - 45$	–	ns
$t_{PLIV}$	$\overline{\text{PSEN}}$ LOW to valid instruction in	–	145	–	83	–	$3t_{clk} - 105$	ns
$t_{PXIX}$	input instruction hold after $\overline{\text{PSEN}}$	0	–	0	–	0	–	ns
$t_{PXIZ}$	input instruction float after $\overline{\text{PSEN}}$	–	59	–	38	–	$t_{clk} - 25$	ns
$t_{AVIV}$	address to valid instruction in	–	312	–	208	–	$5t_{clk} - 105$	ns
$t_{PLAZ}$	$\overline{\text{PSEN}}$ LOW to address float	–	10	–	10	–	10	ns
<b>External Data Memory; see Fig.28</b>								
$t_{RLRH}$	$\overline{\text{RD}}$ pulse width	400	–	275	–	$6t_{clk} - 100$	–	ns
$t_{WLWH}$	$\overline{\text{WR}}$ pulse width	400	–	275	–	$6t_{clk} - 100$	–	ns
$t_{AVLL}$	address valid to ALE LOW	43	–	23	–	$t_{clk} - 40$	–	ns
$t_{LLAX}$	address hold after ALE LOW	48	–	28	–	$t_{clk} - 35$	–	ns
$t_{RLDV}$	$\overline{\text{RD}}$ LOW to valid data in	–	252	–	148	–	$5t_{clk} - 165$	ns
$t_{RHDX}$	data hold after $\overline{\text{RD}}$	0	–	0	–	0	–	ns
$t_{RHDZ}$	data float after $\overline{\text{RD}}$	–	97	–	55	–	$2t_{clk} - 70$	ns
$t_{LLDV}$	ALE LOW to valid data in	–	517	–	350	–	$8t_{clk} - 150$	ns
$t_{AVDV}$	address to valid data in	–	585	–	398	–	$9t_{clk} - 165$	ns
$t_{LLWL}$	ALE LOW to $\overline{\text{RD}}$ or $\overline{\text{WR}}$ LOW	200	300	138	238	$3t_{clk} - 50$	$3t_{clk} + 50$	ns
$t_{AVWL}$	address valid to $\overline{\text{RD}}$ or $\overline{\text{WR}}$ LOW	203	–	120	–	$4t_{clk} - 130$	–	ns
$t_{WHLH}$	$\overline{\text{RD}}$ or $\overline{\text{WR}}$ HIGH to ALE HIGH	43	123	23	103	$t_{clk} - 40$	$t_{clk} + 40$	ns
$t_{QVWX}$	data valid to $\overline{\text{WR}}$ transition	33	–	13	–	$t_{clk} - 50$	–	ns
$t_{QVWH}$	data valid time $\overline{\text{WR}}$ HIGH	433	–	288	–	$7t_{clk} - 150$	–	ns
$t_{WHQX}$	data hold after $\overline{\text{WR}}$	33	–	13	–	$t_{clk} - 50$	–	ns
$t_{RLAZ}$	$\overline{\text{RD}}$ LOW to address float	–	0	–	0	–	0	ns
<b>UART Timing - Shift Register Mode; see Fig.30</b>								
$t_{XLXL}$	serial port clock cycle time	1.0	–	0.75	–	$12t_{clk}$	–	$\mu\text{s}$
$t_{QVXH}$	output data setup to clock rising edge	700	–	492	–	$10t_{clk} - 133$	–	ns
$t_{XHQX}$	SCL clock frequency	50	–	8	–	$2t_{clk} - 117$	–	ns
$t_{XHDX}$	input data hold after clock rising edge	0	–	0	–	0	–	ns
$t_{XHDX}$	clock rising edge to input data valid	–	700	–	492	–	$10t_{clk} - 133$	ns

## 8-bit microcontroller

## P8xC557E8

**Table 82** I<sup>2</sup>C-bus interface timingAll values referred to  $V_{IH(min)}$  and  $V_{IL(max)}$  levels; see Fig.31.

SYMBOL	PARAMETER	I <sup>2</sup> C-BUS				UNIT
		STANDARD MODE		FAST MODE		
		MIN.	MAX.	MIN.	MAX.	
$f_{SCL}$	SCL clock frequency	0	100	0	400	kHz
$t_{BUF}$	bus free time between STOP and START condition	4.7	–	1.3	–	$\mu$ s
$t_{HD;STA}$	hold time (repeated) START condition; after this period, the first clock pulse is generated	4.0	–	0.6	–	$\mu$ s
$t_{LOW}$	LOW period of the SCL clock	4.7	–	1.3	–	$\mu$ s
$t_{HIGH}$	HIGH period of the SCL clock	4.0	–	0.6	–	$\mu$ s
$t_{SU;STA}$	set-up time for a repeated START condition	4.7	–	0.6	–	$\mu$ s
$t_{HD;DAT}$	data hold time: for CBUS compatible masters (see Chapter 21; notes 1 and 3)	5.0	–	–	–	$\mu$ s
	for I <sup>2</sup> C-bus devices (notes 1 and 2)	0	–	0	0.9	$\mu$ s
$t_{SU;DAT}$	data set-up time	250	–	100 <sup>(3)</sup>	–	ns
$t_{RD}; t_{RC}$	rise time of SDA and SCL signals	–	1000	20 + 0.1C <sub>b</sub> <sup>(4)</sup>	300	ns
$t_{FD}; t_{FC}$	fall time of SDA and SCL signals	–	300			
$t_{SU;STO}$	set-up time for STOP condition	4.0	–	0.6	–	$\mu$ s
C <sub>b</sub>	capacitive load for each bus line	–	400	–	400	pF
$t_{SP}$	pulse width of spikes which must be suppressed by the input filter	–	–	0	50	ns

**Notes**

1. A device must internally provide a hold time of at least 300 ns for the SDA signal (referred to the  $V_{IHmin}$  of the SCL signal) in order to bridge the undefined region of the falling edge of SCL.
2. The maximum  $t_{HD;DAT}$  has only to be met if the device does not stretch the LOW period ( $t_{LOW}$ ) of the SCL signal.
3. A fast-mode I<sup>2</sup>C-bus device can be used in a standard-mode I<sup>2</sup>C-bus system, but the requirement  $t_{SU, DAT} > 250$  ns must then be met. This will automatically be the case if the device does not stretch the LOW period of the SCL signal. If such a device does stretch the LOW period of the SCL signal, it must output the next data bit to the SDA line  $t_{R(max)} + t_{SU, DAT} = 1000 + 250 = 1250$  ns (according to the standard-mode I<sup>2</sup>C-bus specification) before the SCL line is released.
4. C<sub>b</sub> = total capacitance of one bus line in pF.

8-bit microcontroller

P8xC557E8

**Table 83** External clock drive XTAL1

SYMBOL	PARAMETER	VARIABLE CLOCK ( $f_{clk} = 3.5$ to $16$ MHz)		UNIT
		MIN.	MAX.	
$t_{clk}$	oscillator clock period	63	286	ns
$t_{HIGH}$	HIGH time	20	$t_{clk} - t_{LOW}$	ns
$t_{LOW}$	LOW time	20	$t_{clk} - t_{HIGH}$	ns
$t_r$	rise time	–	20	ns
$t_f$	fall time	–	20	ns
$t_{CYC}$	cycle time ( $12 \times t_{clk}$ )	0.75	3.4	$\mu s$

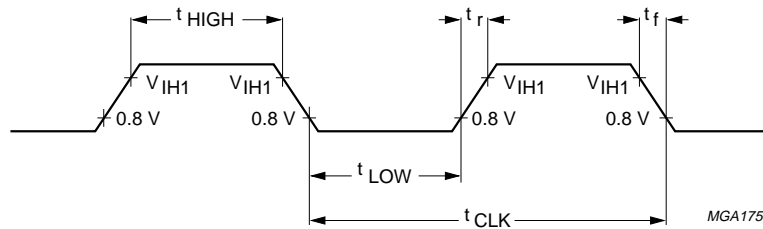
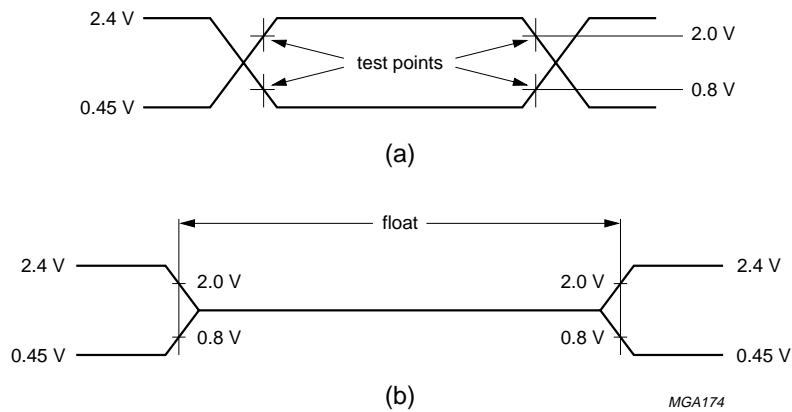

Fig.24 External clock drive XTAL1.



AC testing inputs are driven at 2.4 V for a HIGH and 0.45 V for a LOW.

Timing measurements are taken at 2.0 V for a HIGH and 0.8 V for a LOW, see Fig.25 (a).

The float state is defined as the point at which a Port 0 pin sinks 3.2 mA or sources 400  $\mu A$  at the voltage test levels, see Fig.25 (b).

Fig.25 AC testing input, output waveform (a) and float waveform (b).

8-bit microcontroller

P8xC557E8

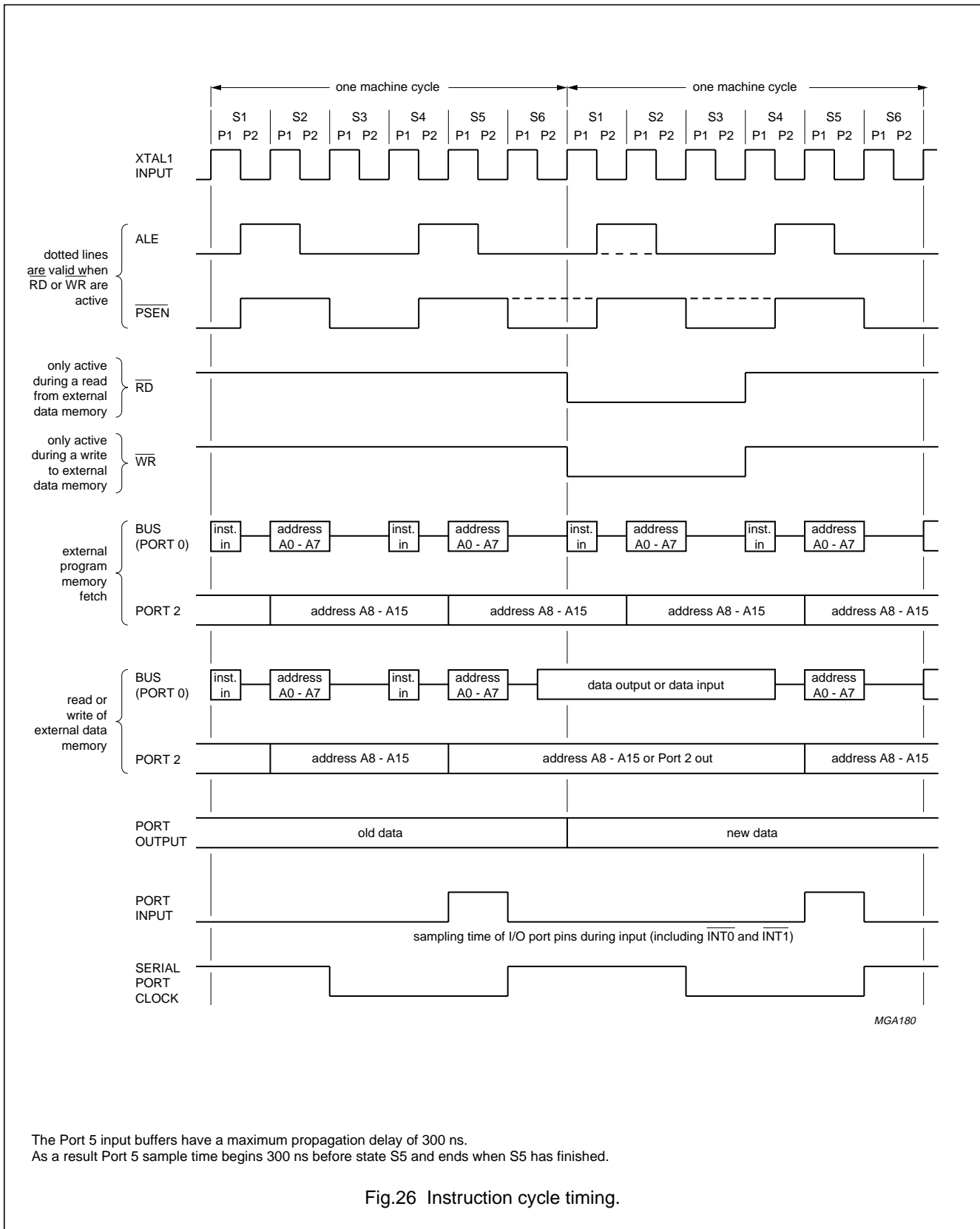

The Port 5 input buffers have a maximum propagation delay of 300 ns.  
 As a result Port 5 sample time begins 300 ns before state S5 and ends when S5 has finished.

Fig.26 Instruction cycle timing.

8-bit microcontroller

P8xC557E8

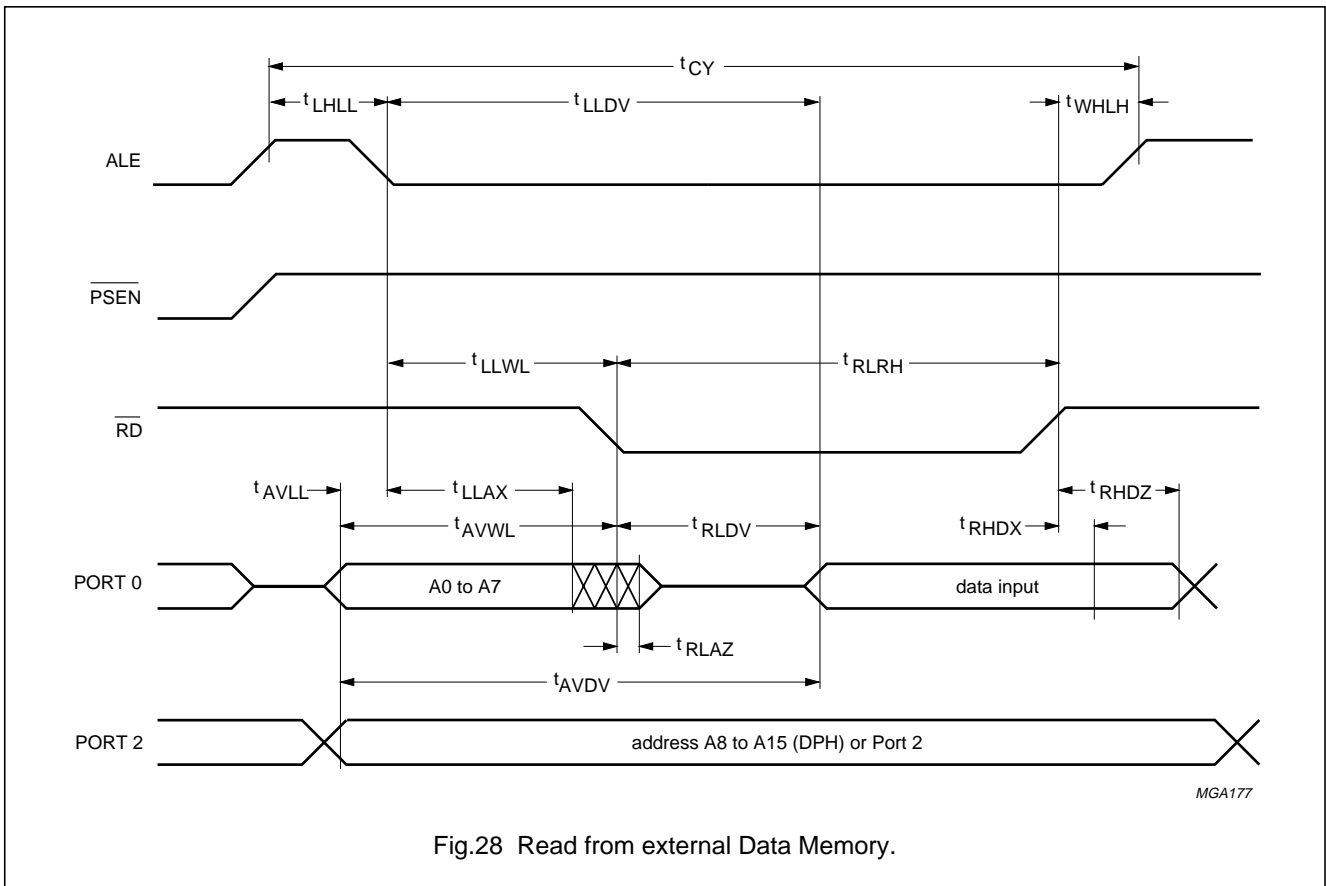
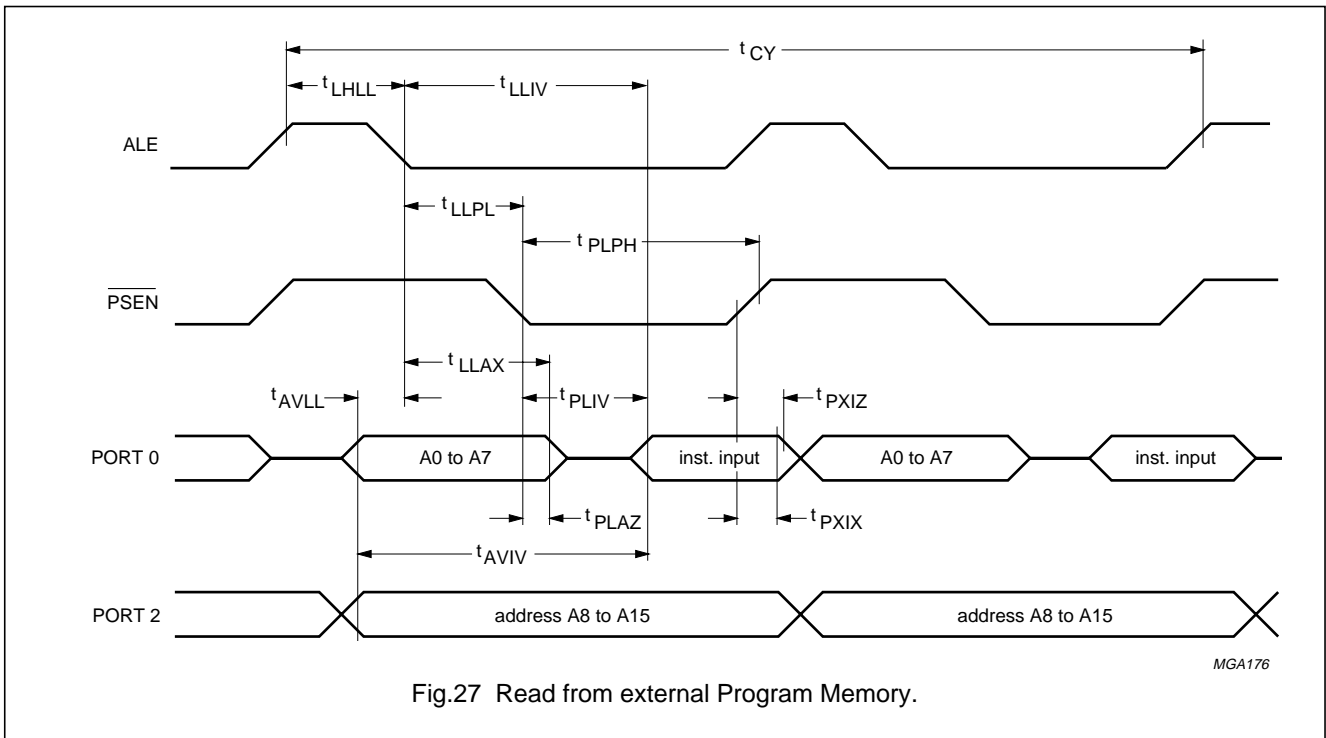

8-bit microcontroller

P8xC557E8

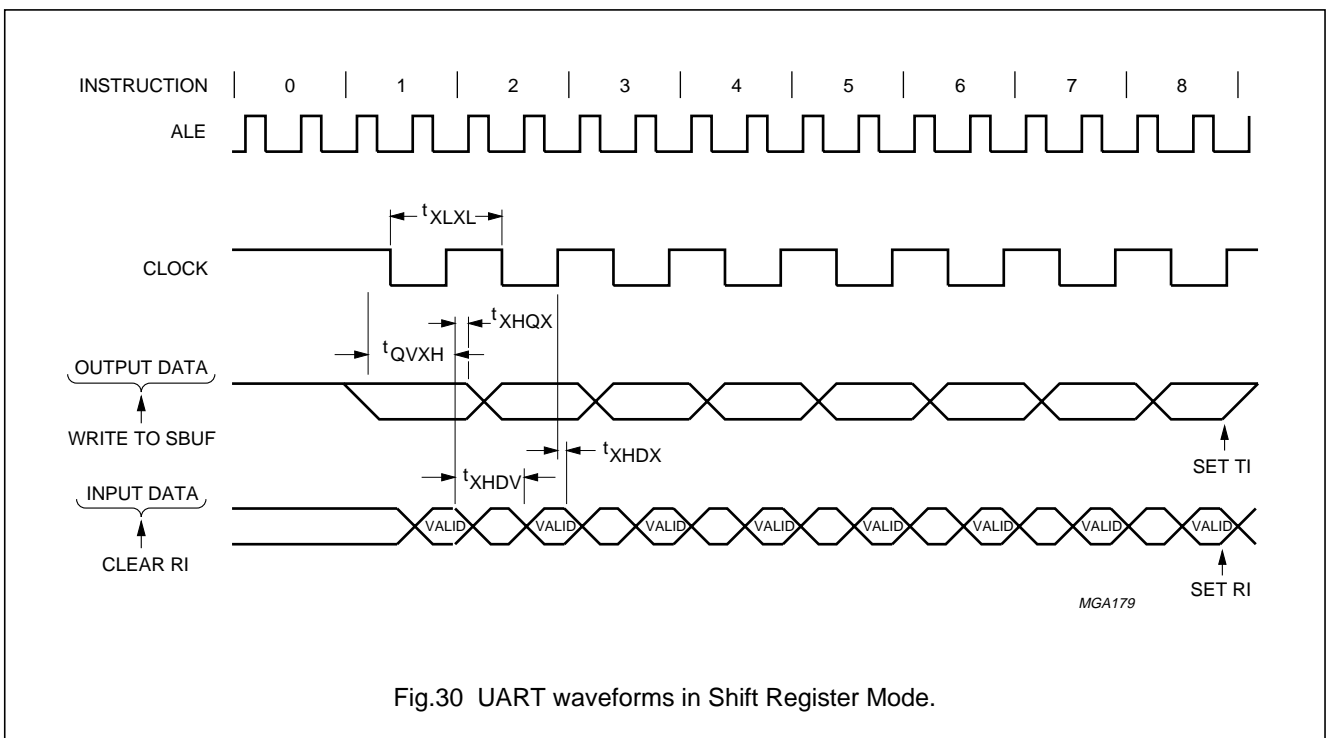
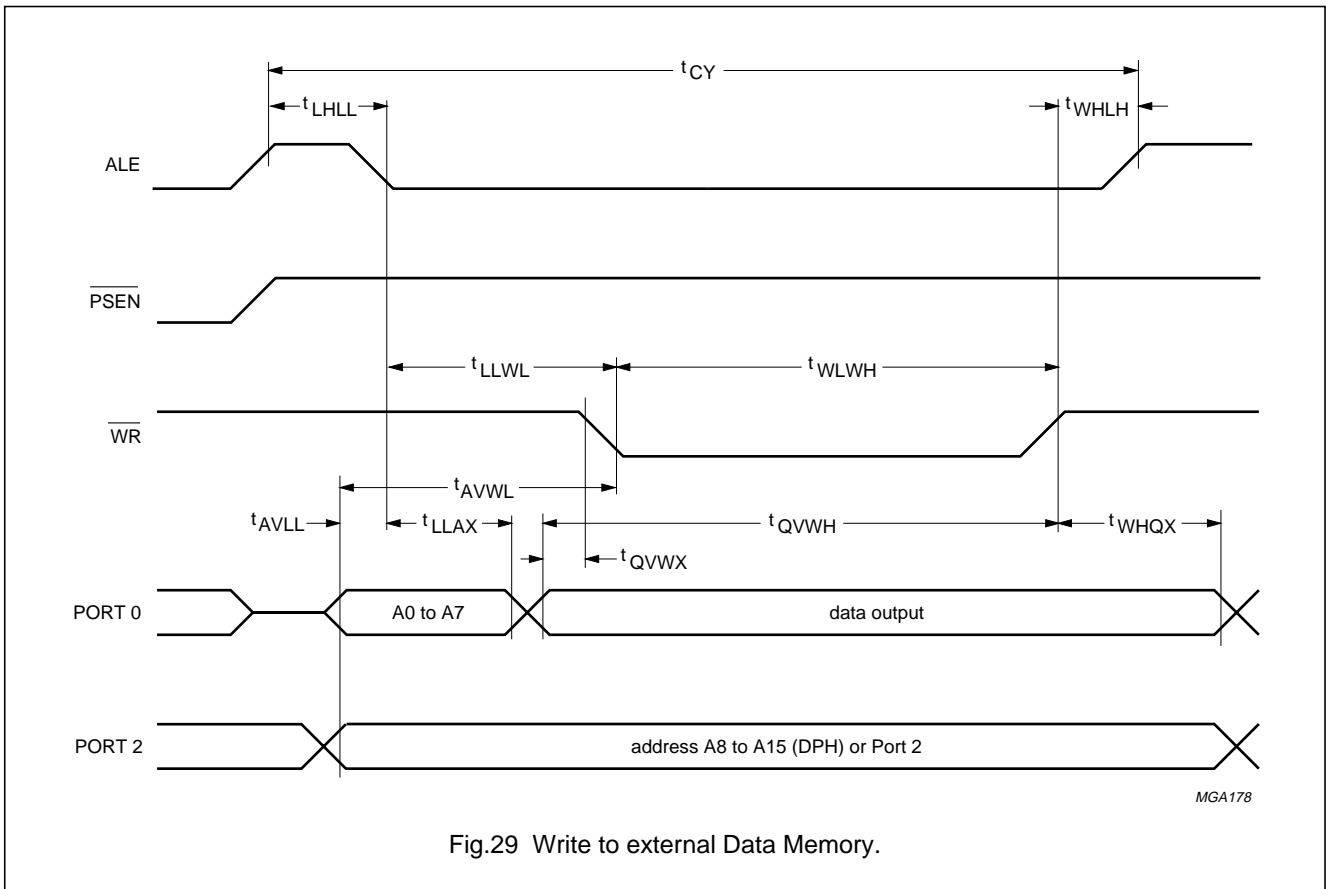



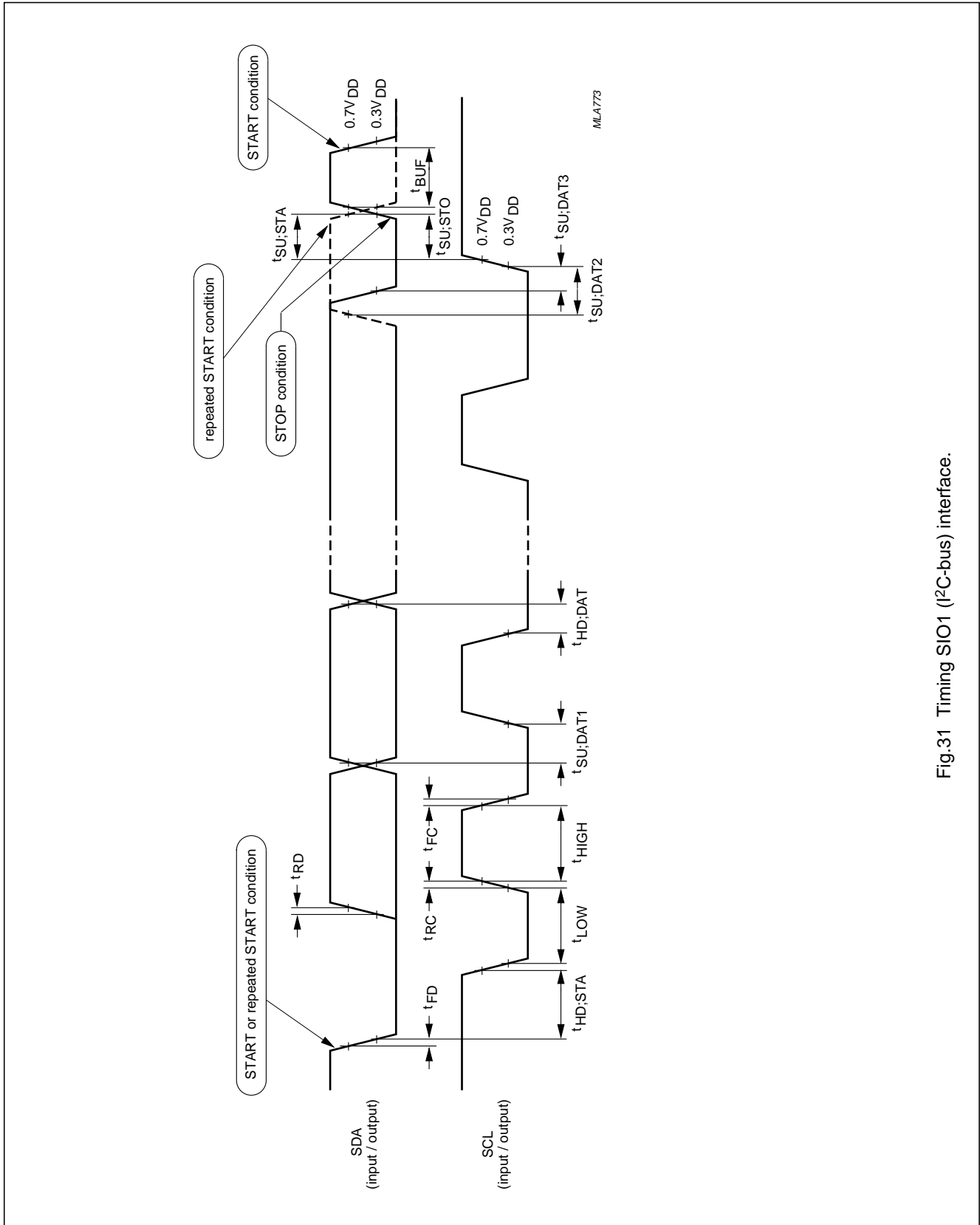

Fig.31 Timing SIO1 (I<sup>2</sup>C-bus) interface.

## 8-bit microcontroller

## P8xC557E8

**23 EPROM CHARACTERISTICS**

The P87C557E8 has an on-chip 64 kbytes EPROM for fast and flexible controller software development. It is available as an OTP-version in a plastic QFP package, P87C557E8EFB, which is not erasable.

**23.1 Programming and verification**

The P87C557E8 is programmed by using a modified Quick-Pulse Programming algorithm (Trademark algorithm of Intel Corporation).

In Table 85, the logic levels for reading the Signature bytes and for programming the Program Memory, the Encryption Table and the Lock bits are listed.

The circuit configuration and waveforms for programming are shown in the Figs 32 and 33. Figure 34 shows the circuit configuration for code data verification.

Note that programming and verification is done with an oscillator frequency of 4 to 6 MHz. The two Signature bytes identifying the device as an P87C557E8 manufactured by Philips are located as shown in Table 84.

**Table 84** Programming and Verification

ADDRESS	CONTENT	MEANING
30H	15H	Philips
31H	C3H	P87C557E8

**23.2 Security**

For code protection the P87C557E8 has an Encryption table and three Lock bits (LB1, LB2 and LB3). After programming the Encryption table from addresses 00H to 3FH, a verification sequence will present the data at Port 0 as a logical EXNOR of the program byte with one of the Encryption bytes. The Encryption table is not readable.

The P87C557E8 has 3 programmable Lock bits which must be programmed according to Table 85 to provide different levels of protection of the on-chip code and data. Erasing the EPROM also erases the encryption array and the program lock bits, returning the part to full functionality. The lock bits cannot be directly verified. Verification of the lock bits is done by observing that their features are enabled.

**Table 85** Protection Level 69Programming

P = programmed; U = unprogrammed.

PROTECTION LEVEL	LB1	LB2	LB3	PROTECTION DESCRIPTION
1	U	U	U	No Program Lock features enabled. (Code verify will still be encrypted by the Encryption Array if programmed.)
2	P	U	U	MOVC instructions executed from external Program Memory are disabled from fetching code bytes from internal memory, $\overline{EA}$ is sampled and latched on reset, and further programming of the EPROM is disabled.
3	P	P	U	Same as Protection Level 2 and also verify is disabled.
4	P	P	P	Same as Protection Level 3 and external memory execution by forcing $\overline{EA} = \text{LOW}$ is disabled.

8-bit microcontroller

P8xC557E8

**Table 86** EPROM programming modes

MODE	RSTIN	$\overline{\text{PSEN}}$	$\overline{\text{ALE/PROG}}$	$\overline{\text{EA/V}}_{\text{PP}}$	P2.7	P2.6	P3.7	P3.6	P3.3
Read Signature	HIGH	LOW	HIGH	HIGH	LOW	LOW	LOW	LOW	LOW
Program code data	HIGH	LOW	LOW <sup>(1)</sup>	$V_{\text{PP}}^{(2)}$	HIGH	LOW	HIGH	HIGH	HIGH
Verify code data	HIGH	LOW	HIGH	HIGH	LOW	LOW	HIGH	HIGH	LOW
Program Encryption table	HIGH	LOW	LOW <sup>(1)</sup>	$V_{\text{PP}}^{(2)}$	HIGH	LOW	HIGH	LOW	HIGH
Program Lock bit 1	HIGH	LOW	LOW <sup>(1)</sup>	$V_{\text{PP}}^{(2)}$	HIGH	HIGH	HIGH	HIGH	HIGH
Program Lock bit 2	HIGH	LOW	LOW <sup>(1)</sup>	$V_{\text{PP}}^{(2)}$	HIGH	HIGH	LOW	LOW	HIGH
Program Lock bit 3	HIGH	LOW	LOW <sup>(1)</sup>	$V_{\text{PP}}^{(2)}$	LOW	HIGH	LOW	HIGH	HIGH

**Notes**

- Each programming pulse is:
  - LOW for  $50 \pm 5 \mu\text{s}$ .
  - HIGH for at least  $5 \mu\text{s}$ .
- $\overline{\text{ALE/PROG}}$  receives 5 programming pulses while  $V_{\text{PP}}$  is held at  $12.75 \pm 0.25 \text{ V}$ .

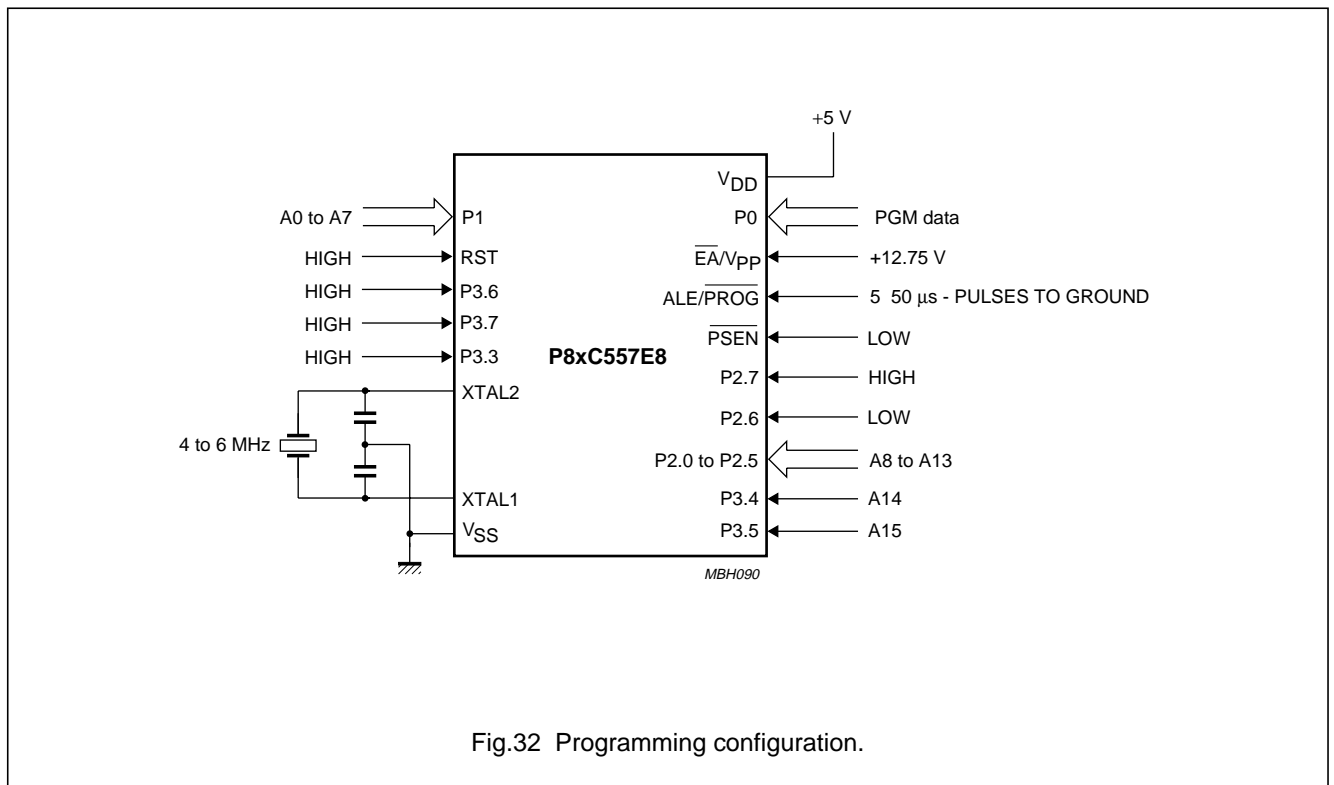
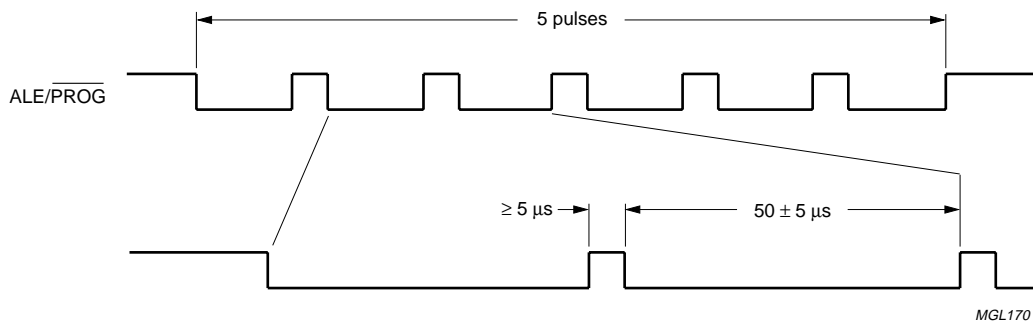

Fig.32 Programming configuration.

8-bit microcontroller

P8xC557E8



MGL170

Fig.33  $\overline{\text{PROG}}$  waveform.

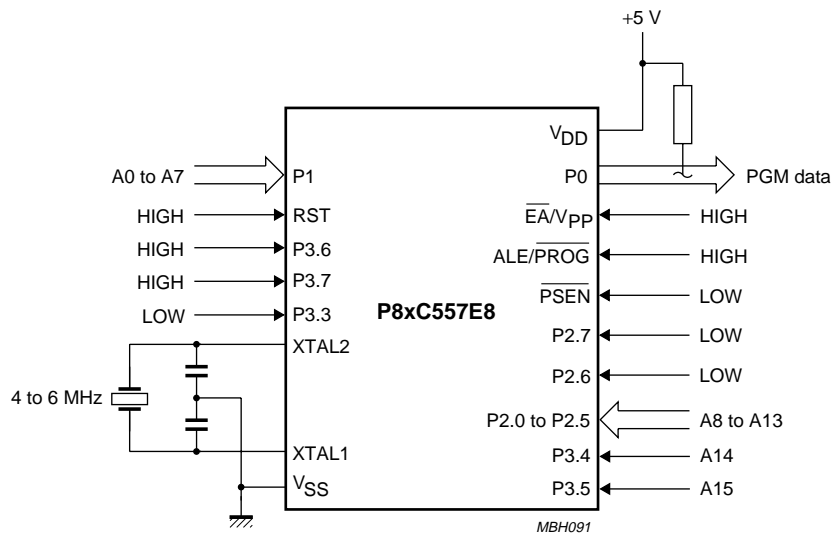

MBH091

Fig.34 Program verification P87C557E8.

8-bit microcontroller

P8xC557E8

**Table 87** EPROM programming and verification characteristics

$V_{DD} = 5 V \pm 10\%$ ;  $V_{SS} = 0 V$ ;  $T_{amb} = 21\text{ }^{\circ}C$  to  $27\text{ }^{\circ}C$ .

SYMBOL	PARAMETER	MIN.	MAX.	UNIT
$V_{PP}$	programming supply voltage	12.5	13.0	V
$I_{PP}$	programming supply current	–	50	mA
$f_{clk}$	oscillator frequency	4	6	MHz
$t_{AVGL}$	address set-up to $\overline{PROG}$ LOW	$48 t_{clk}$	–	
$t_{GHAX}$	address hold after $\overline{PROG}$ HIGH	$48 t_{clk}$	–	
$t_{DVGL}$	data set-up to $\overline{PROG}$ LOW	$48 t_{clk}$	–	
$t_{GHDX}$	data hold after $\overline{PROG}$ HIGH	$48 t_{clk}$	–	
$t_{EHS}$	P2.7 ( $\overline{ENABLE}$ ) HIGH to $V_{pp}$	$48 t_{clk}$	–	
$t_{SHGL}$	$V_{pp}$ set-up to $\overline{PROG}$ LOW	10	–	$\mu s$
$t_{GHSL}$	$V_{pp}$ hold after $\overline{PROG}$ HIGH	10	–	$\mu s$
$t_{GLGH}$	$\overline{PROG}$ pulse width	45	55	$\mu s$
$t_{AVQV}$	address to data valid	–	$48 t_{clk}$	
$t_{ELQV}$	P2.7 ( $\overline{ENABLE}$ ) LOW to data valid	–	$48 t_{clk}$	
$t_{EHQZ}$	data float after P2.7 ( $\overline{ENABLE}$ ) HIGH	0	$48 t_{clk}$	
$t_{GHGL}$	$\overline{PROG}$ HIGH to $\overline{PROG}$ LOW	5	–	$\mu s$

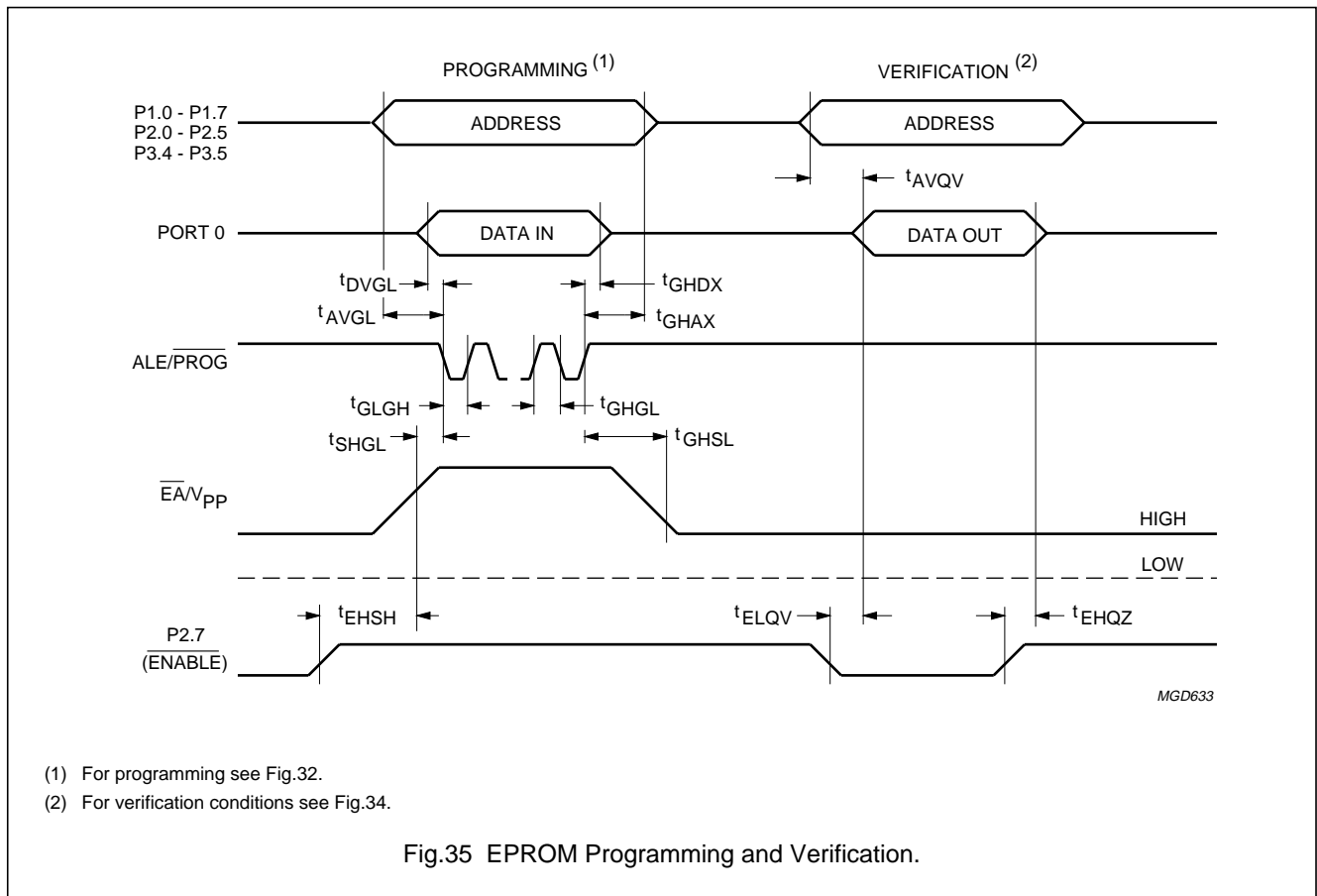

Fig.35 EPROM Programming and Verification.

8-bit microcontroller

P8xC557E8

24 PACKAGE OUTLINE

**QFP80: plastic quad flat package;**  
**80 leads (lead length 1.95 mm); body 14 x 20 x 2.7 mm; high stand-off height**

**SOT318-1**

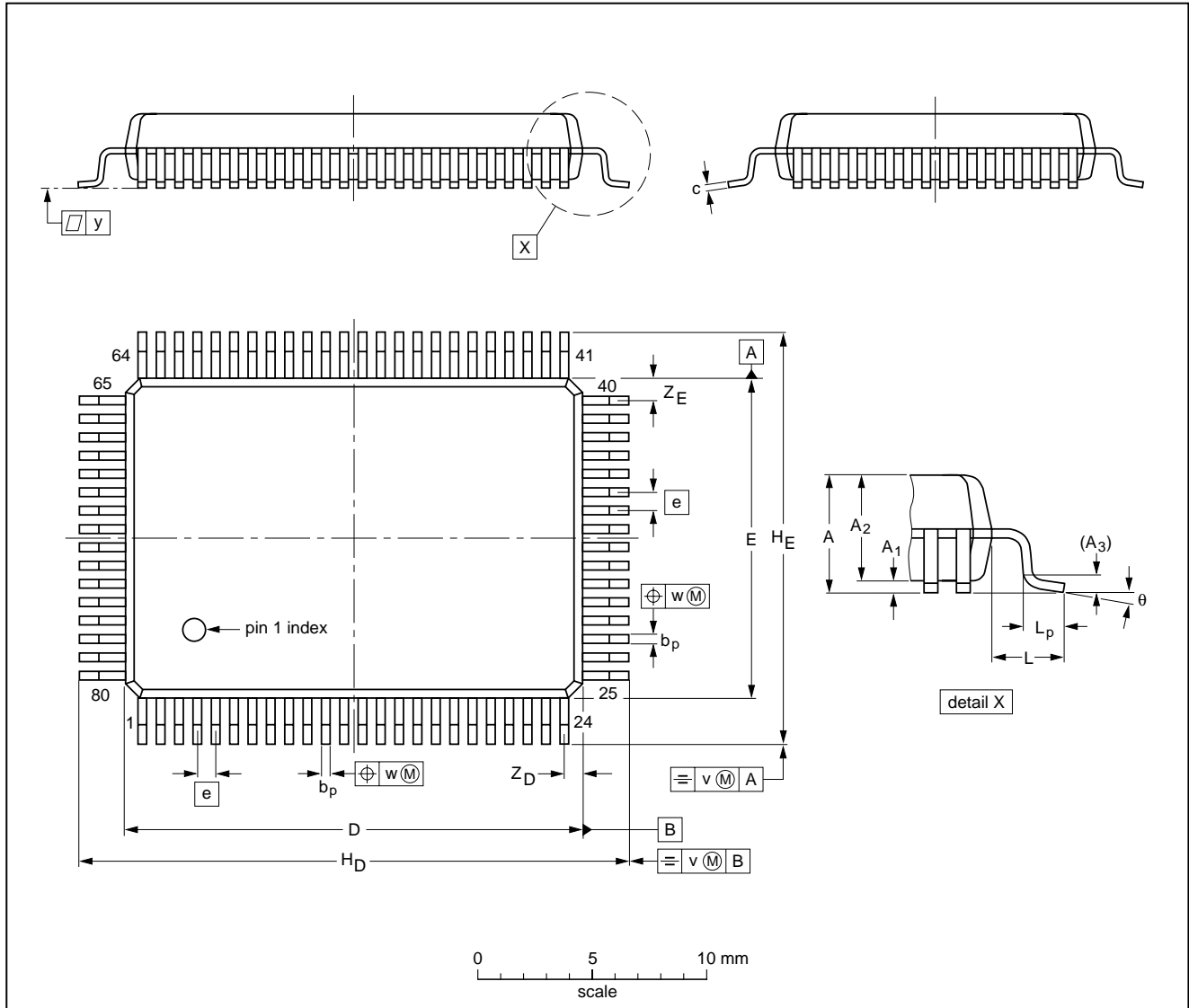

**DIMENSIONS (mm are the original dimensions)**

UNIT	A max.	A <sub>1</sub>	A <sub>2</sub>	A <sub>3</sub>	b <sub>p</sub>	c	D <sup>(1)</sup>	E <sup>(1)</sup>	e	H <sub>D</sub>	H <sub>E</sub>	L	L <sub>p</sub>	v	w	y	Z <sub>D</sub> <sup>(1)</sup>	Z <sub>E</sub> <sup>(1)</sup>	θ
mm	3.3	0.36 0.10	2.87 2.57	0.25	0.45 0.30	0.25 0.13	20.1 19.9	14.1 13.9	0.8	24.2 23.6	18.2 17.6	1.95	1.0 0.6	0.2	0.2	0.1	1.0 0.6	1.2 0.8	7° 0°

**Note**

1. Plastic or metal protrusions of 0.25 mm maximum per side are not included.

OUTLINE VERSION	REFERENCES			EUROPEAN PROJECTION	ISSUE DATE
	IEC	JEDEC	EIAJ		
SOT318-1					95-02-04 97-08-01

## 8-bit microcontroller

## P8xC557E8

### 25 SOLDERING

#### 25.1 Introduction

There is no soldering method that is ideal for all IC packages. Wave soldering is often preferred when through-hole and surface mounted components are mixed on one printed-circuit board. However, wave soldering is not always suitable for surface mounted ICs, or for printed-circuits with high population densities. In these situations reflow soldering is often used.

This text gives a very brief insight to a complex technology. A more in-depth account of soldering ICs can be found in our "IC Package Databook" (order code 9398 652 90011).

#### 25.2 Reflow soldering

Reflow soldering techniques are suitable for all QFP packages.

The choice of heating method may be influenced by larger plastic QFP packages (44 leads, or more). If infrared or vapour phase heating is used and the large packages are not absolutely dry (less than 0.1% moisture content by weight), vaporization of the small amount of moisture in them can cause cracking of the plastic body. For more information, refer to the Drypack chapter in our "Quality Reference Handbook" (order code 9397 750 00192).

Reflow soldering requires solder paste (a suspension of fine solder particles, flux and binding agent) to be applied to the printed-circuit board by screen printing, stencilling or pressure-syringe dispensing before package placement.

Several techniques exist for reflowing; for example, thermal conduction by heated belt. Dwell times vary between 50 and 300 seconds depending on heating method. Typical reflow temperatures range from 215 to 250 °C.

Preheating is necessary to dry the paste and evaporate the binding agent. Preheating duration: 45 minutes at 45 °C.

#### 25.3 Wave soldering

Wave soldering is **not** recommended for QFP packages. This is because of the likelihood of solder bridging due to closely-spaced leads and the possibility of incomplete solder penetration in multi-lead devices.

**If wave soldering cannot be avoided, the following conditions must be observed:**

- **A double-wave (a turbulent wave with high upward pressure followed by a smooth laminar wave) soldering technique should be used.**
- **The footprint must be at an angle of 45° to the board direction and must incorporate solder thieves downstream and at the side corners.**

**Even with these conditions, do not consider wave soldering the following packages: QFP52 (SOT379-1), QFP100 (SOT317-1), QFP100 (SOT317-2), QFP100 (SOT382-1) or QFP160 (SOT322-1).**

During placement and before soldering, the package must be fixed with a droplet of adhesive. The adhesive can be applied by screen printing, pin transfer or syringe dispensing. The package can be soldered after the adhesive is cured.

Maximum permissible solder temperature is 260 °C, and maximum duration of package immersion in solder is 10 seconds, if cooled to less than 150 °C within 6 seconds. Typical dwell time is 4 seconds at 250 °C.

A mildly-activated flux will eliminate the need for removal of corrosive residues in most applications.

#### 25.4 Repairing soldered joints

Fix the component by first soldering two diagonally-opposite end leads. Use only a low voltage soldering iron (less than 24 V) applied to the flat part of the lead. Contact time must be limited to 10 seconds at up to 300 °C. When using a dedicated tool, all other leads can be soldered in one operation within 2 to 5 seconds between 270 and 320 °C.

## 8-bit microcontroller

P8xC557E8

**26 DEFINITIONS**

<b>Data sheet status</b>	
Objective specification	This data sheet contains target or goal specifications for product development.
Preliminary specification	This data sheet contains preliminary data; supplementary data may be published later.
Product specification	This data sheet contains final product specifications.
<b>Limiting values</b>	
Limiting values given are in accordance with the Absolute Maximum Rating System (IEC 134). Stress above one or more of the limiting values may cause permanent damage to the device. These are stress ratings only and operation of the device at these or at any other conditions above those given in the Characteristics sections of the specification is not implied. Exposure to limiting values for extended periods may affect device reliability.	
<b>Application information</b>	
Where application information is given, it is advisory and does not form part of the specification.	

**27 LIFE SUPPORT APPLICATIONS**

These products are not designed for use in life support appliances, devices, or systems where malfunction of these products can reasonably be expected to result in personal injury. Philips customers using or selling these products for use in such applications do so at their own risk and agree to fully indemnify Philips for any damages resulting from such improper use or sale.

**28 PURCHASE OF PHILIPS I<sup>2</sup>C COMPONENTS**

Purchase of Philips I<sup>2</sup>C components conveys a license under the Philips' I<sup>2</sup>C patent to use the components in the I<sup>2</sup>C system provided the system conforms to the I<sup>2</sup>C specification defined by Philips. This specification can be ordered using the code 9398 393 40011.



8-bit microcontroller

P8xC557E8

---

**NOTES**

8-bit microcontroller

P8xC557E8

---

**NOTES**

8-bit microcontroller

P8xC557E8

---

**NOTES**

# Philips Semiconductors – a worldwide company

**Argentina:** see South America

**Australia:** 34 Waterloo Road, NORTH RYDE, NSW 2113,  
Tel. +61 2 9805 4455, Fax. +61 2 9805 4466

**Austria:** Computerstr. 6, A-1101 WIEN, P.O. Box 213, Tel. +43 160 1010,  
Fax. +43 160 101 1210

**Belarus:** Hotel Minsk Business Center, Bld. 3, r. 1211, Volodarski Str. 6,  
220050 MINSK, Tel. +375 172 200 733, Fax. +375 172 200 773

**Belgium:** see The Netherlands

**Brazil:** see South America

**Bulgaria:** Philips Bulgaria Ltd., Energoproject, 15th floor,  
51 James Bourchier Blvd., 1407 SOFIA,  
Tel. +359 2 689 211, Fax. +359 2 689 102

**Canada:** PHILIPS SEMICONDUCTORS/COMPONENTS,  
Tel. +1 800 234 7381

**China/Hong Kong:** 501 Hong Kong Industrial Technology Centre,  
72 Tat Chee Avenue, Kowloon Tong, HONG KONG,  
Tel. +852 2319 7888, Fax. +852 2319 7700

**Colombia:** see South America

**Czech Republic:** see Austria

**Denmark:** Prags Boulevard 80, PB 1919, DK-2300 COPENHAGEN S,  
Tel. +45 32 88 2636, Fax. +45 31 57 0044

**Finland:** Sinikalliontie 3, FIN-02630 ESPOO,  
Tel. +358 9 615800, Fax. +358 9 61580920

**France:** 4 Rue du Port-aux-Vins, BP317, 92156 SURESNES Cedex,  
Tel. +33 1 40 99 6161, Fax. +33 1 40 99 6427

**Germany:** Hammerbrookstraße 69, D-20097 HAMBURG,  
Tel. +49 40 23 53 60, Fax. +49 40 23 536 300

**Greece:** No. 15, 25th March Street, GR 17778 TAVROS/ATHENS,  
Tel. +30 1 4894 339/239, Fax. +30 1 4814 240

**Hungary:** see Austria

**India:** Philips INDIA Ltd, Band Box Building, 2nd floor,  
254-D, Dr. Annie Besant Road, Worli, MUMBAI 400 025,  
Tel. +91 22 493 8541, Fax. +91 22 493 0966

**Indonesia:** see Singapore

**Ireland:** Newstead, Clonskeagh, DUBLIN 14,  
Tel. +353 1 7640 000, Fax. +353 1 7640 200

**Israel:** RAPAC Electronics, 7 Kehilat Saloniki St, PO Box 18053,  
TEL AVIV 61180, Tel. +972 3 645 0444, Fax. +972 3 649 1007

**Italy:** PHILIPS SEMICONDUCTORS, Piazza IV Novembre 3,  
20124 MILANO, Tel. +39 2 6752 2531, Fax. +39 2 6752 2557

**Japan:** Philips Bldg 13-37, Kohnan 2-chome, Minato-ku, TOKYO 108,  
Tel. +81 3 3740 5130, Fax. +81 3 3740 5077

**Korea:** Philips House, 260-199 Itaewon-dong, Yongsan-ku, SEOUL,  
Tel. +82 2 709 1412, Fax. +82 2 709 1415

**Malaysia:** No. 76 Jalan Universiti, 46200 PETALING JAYA, SELANGOR,  
Tel. +60 3 750 5214, Fax. +60 3 757 4880

**Mexico:** 5900 Gateway East, Suite 200, EL PASO, TEXAS 79905,  
Tel. +9-5 800 234 7381

**Middle East:** see Italy

**Netherlands:** Postbus 90050, 5600 PB EINDHOVEN, Bldg. VB,  
Tel. +31 40 27 82785, Fax. +31 40 27 88399

**New Zealand:** 2 Wagener Place, C.P.O. Box 1041, AUCKLAND,  
Tel. +64 9 849 4160, Fax. +64 9 849 7811

**Norway:** Box 1, Manglerud 0612, OSLO,  
Tel. +47 22 74 8000, Fax. +47 22 74 8341

**Philippines:** Philips Semiconductors Philippines Inc.,  
106 Valero St. Salcedo Village, P.O. Box 2108 MCC, MAKATI,  
Metro MANILA, Tel. +63 2 816 6380, Fax. +63 2 817 3474

**Poland:** Ul. Lukiska 10, PL 04-123 WARSZAWA,  
Tel. +48 22 612 2831, Fax. +48 22 612 2327

**Portugal:** see Spain

**Romania:** see Italy

**Russia:** Philips Russia, Ul. Usatcheva 35A, 119048 MOSCOW,  
Tel. +7 095 755 6918, Fax. +7 095 755 6919

**Singapore:** Lorong 1, Toa Payoh, SINGAPORE 1231,  
Tel. +65 350 2538, Fax. +65 251 6500

**Slovakia:** see Austria

**Slovenia:** see Italy

**South Africa:** S.A. PHILIPS Pty Ltd., 195-215 Main Road Martindale,  
2092 JOHANNESBURG, P.O. Box 7430 Johannesburg 2000,  
Tel. +27 11 470 5911, Fax. +27 11 470 5494

**South America:** Rua do Rocio 220, 5th floor, Suite 51,  
04552-903 São Paulo, SÃO PAULO - SP, Brazil,  
Tel. +55 11 821 2333, Fax. +55 11 829 1849

**Spain:** Balmes 22, 08007 BARCELONA,  
Tel. +34 3 301 6312, Fax. +34 3 301 4107

**Sweden:** Kottbygatan 7, Akalla, S-16485 STOCKHOLM,  
Tel. +46 8 632 2000, Fax. +46 8 632 2745

**Switzerland:** Allmendstrasse 140, CH-8027 ZÜRICH,  
Tel. +41 1 488 2686, Fax. +41 1 481 7730

**Taiwan:** Philips Semiconductors, 6F, No. 96, Chien Kuo N. Rd., Sec. 1,  
TAIPEI, Taiwan Tel. +886 2 2134 2865, Fax. +886 2 2134 2874

**Thailand:** PHILIPS ELECTRONICS (THAILAND) Ltd.,  
209/2 Sanpavuth-Bangna Road Prakanong, BANGKOK 10260,  
Tel. +66 2 745 4090, Fax. +66 2 398 0793

**Turkey:** Talatpasa Cad. No. 5, 80640 GÜLTEPE/ISTANBUL,  
Tel. +90 212 279 2770, Fax. +90 212 282 6707

**Ukraine:** PHILIPS UKRAINE, 4 Patrice Lumumba str., Building B, Floor 7,  
252042 KIEV, Tel. +380 44 264 2776, Fax. +380 44 268 0461

**United Kingdom:** Philips Semiconductors Ltd., 276 Bath Road, Hayes,  
MIDDLESEX UB3 5BX, Tel. +44 181 730 5000, Fax. +44 181 754 8421

**United States:** 811 East Arques Avenue, SUNNYVALE, CA 94088-3409,  
Tel. +1 800 234 7381

**Uruguay:** see South America

**Vietnam:** see Singapore

**Yugoslavia:** PHILIPS, Trg N. Pasica 5/v, 11000 BEOGRAD,  
Tel. +381 11 625 344, Fax. +381 11 635 777

**For all other countries apply to:** Philips Semiconductors, Marketing & Sales Communications,  
Building BE-p, P.O. Box 218, 5600 MD EINDHOVEN, The Netherlands, Fax. +31 40 27 24825

**Internet:** <http://www.semiconductors.philips.com>

© Philips Electronics N.V. 1997

SCA55

All rights are reserved. Reproduction in whole or in part is prohibited without the prior written consent of the copyright owner.

The information presented in this document does not form part of any quotation or contract, is believed to be accurate and reliable and may be changed without notice. No liability will be accepted by the publisher for any consequence of its use. Publication thereof does not convey nor imply any license under patent- or other industrial or intellectual property rights.

Printed in The Netherlands

457047/1200/01/pp84

Date of release: 1999 Mar 12

Document order number: 9397 750 02689

*Let's make things better.*

**Philips  
Semiconductors**



**PHILIPS**